



The Plastics Experts.

PE 100 (-RC)

Ø 3500 mm

3260

3000

2830

2720

2500

2300

2250

2000

1800

1600

XXL Piping System

EXCEPTIONAL IN
DIMENSION AND QUALITY



¡Contáctanos!

✉ info@ldm.la

USA +1 480 590 2543
MÉXICO +52 662 108 0020

COLOMBIA +57 601 829 5511
PANAMÁ +507 2 308 7585

PERÚ: +51 01 6145771

AGRU PE 100 (-RC) XXL Piping System

XXL PIPE PRODUCTION FACILITY



The most economical long-term solution for seawater intake / discharge, outfall, sewage and industrial process lines.

Two state-of-the-art production plants for pipes and fittings, sophisticated welding technology, extensive know-how in engineering and logistics. This is just one part of the AGRU service, which provides a customer-related one-stop shopping solution.

We follow our client's needs and support them during the entire project-realization phase – from the beginning to the approval. This qualifies AGRU as the most experienced and reliable EPC partner.



**ISO
9001**

Quality
management
system



**ISO
14001**

Quality
management
system



**ISO
45001**

Occupational
health and safety



**EN
12201**

Plastic piping
systems for water
supply



**ISO
4427**

Plastic piping
systems for water
supply

Polyethylene - material of choice

COST AND TIME SAVING INSTALLATION

- Extremely flexible and lightweight
- Homogeneous and durable welding connections
- Allowing various installation methods
- Fast & safe offshore sinking process
- Reducing manpower on site
- UV resistant

EFFICIENT AND MAINTENANCE-FREE OPERATION

- Smooth surface, perfect flow characteristics
- Resistant against corrosion and abrasion
- Insensitive to pressure surges
(up to 200% of the operating pressure)
- Physiologically safe
- Service life expectancy \geq 100 years
- Fully recyclable

Valuable engineered

RAW MATERIAL

Only pre-compounded (including well dispersed high-grade additives) and virgin resins are used for AGRU XXL pipes which are in conformance to both, PE 100 (-RC) and PE 4710 requirements.



PE 100+association
quality materials only

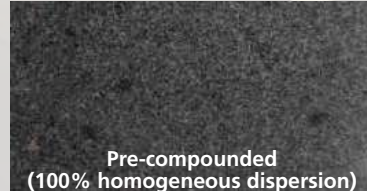

Pre-compounded
(100% homogeneous dispersion)

EMERGING PRODUCTION TECHNOLOGY – DEVELOPED BY AGRU

Due to ongoing innovation in production technology, AGRU expands its leading position for large diameter piping systems and is now producing the world's largest extruded PE 100 (-RC) pressure pipe.

UNCOMPROMISING EXCELLENT QUALITY

AGRU implements stringent quality control, that exceeds international standards. Additionally, each product produced is fully documented and traceable along the entire supply chain – from raw material to the final product.



We provide system solutions

AGRU provides the full dimension range according to current standards. Pipes are produced project specific with seamless lengths up to 600 m.

Pipe supply range

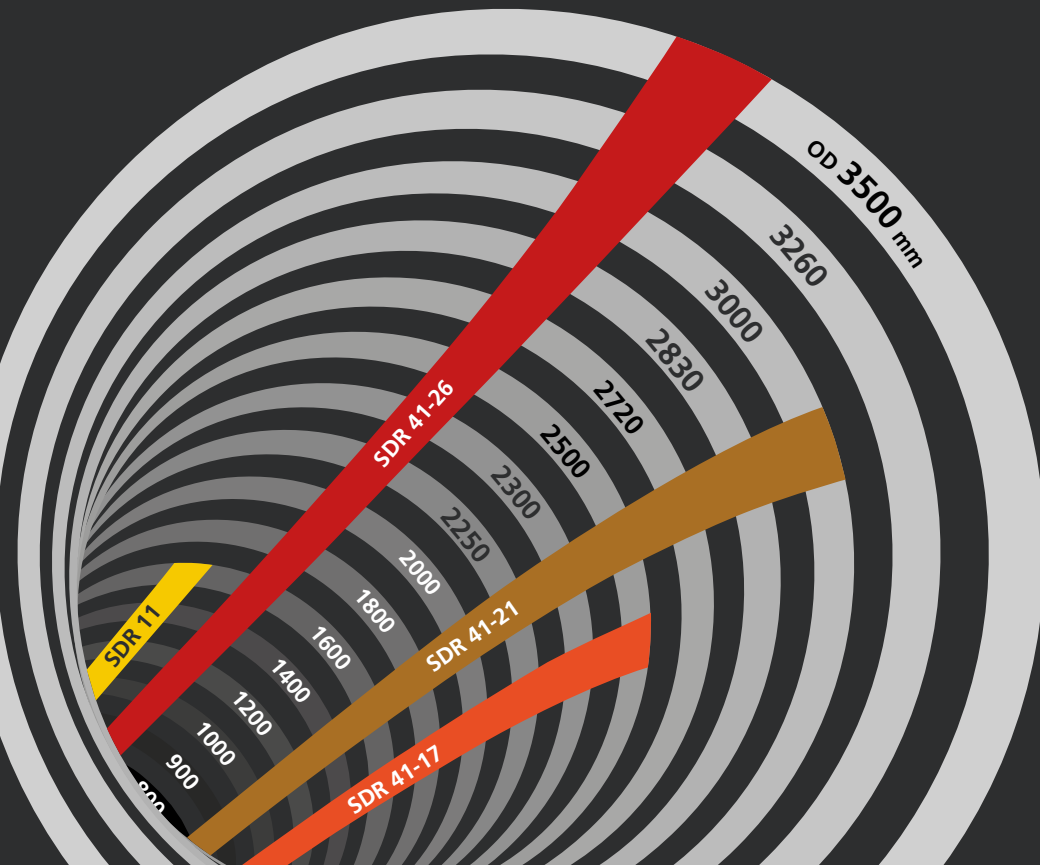

Fitting supply range

AGRU provides a complete system. Fittings are available up to OD 3500 mm acc. to the respective pipe SDR.

FLANGE COMPONENTS

AGRU provides the complete range for durable flange connections including:

- EPDM gaskets with steel inserts
- Backing rings / blind flanges in various steel qualities
- Bolt sets in various steel qualities (screws, nuts, washers)



Bend 11°, 22°, 30°, 45°, 60°, 90°	Tee	Reduced Tee	Stub Flange	Reduction	End Cap	Toploadsaddle
OD [mm]	OD [mm]	OD [mm]	OD [mm]	OD [mm]	OD [mm]	OD / branch Ø [mm]
800	800	800 / ≤700	800	800/630/800/710	800	800 / ≤500
900	900	900 / ≤800	900	900/710/900/800	900	900 / ≤500
1000	1000	1000 / ≤900	1000	1000/900	1000	1000 / ≤500
1200	1200	1200 / ≤1000	1200	1200/1000	1200	1200 / ≤500
1400	1400	1400 / ≤1200	1400	1400/1200		1400 / ≤500
1600	1600	1600 / ≤1400	1600	1600/1400		1600 / ≤900
1800	1800	1800 / ≤1600	1800	1800 / 1600		1800 / ≤900
2000	2000	2000 / ≤1800	2000	2000/1800		2000 / ≤1400
2250	2250	2250 / ≤2000	2250	2250/2000		2250 / ≤1400
2500		2500 / ≤2250	2500	2500/2250		2500 / ≤1400
2720			2720			2720 / ≤1400
2830			2830			2830 / ≤1400
3000			3000			3000 / ≤1400
3260			3260			3260 / ≤1400
3500			3500			3500 / ≤1400

Realizing ideas from scratch to the final product

DESIGN, ENGINEERING, IN-HOUSE FABRICATION

Vast capabilities allow AGRU to provide tailor-made and timely solutions, all from a single source – this qualifies AGRU as the most valuable partner for EPC contractors!

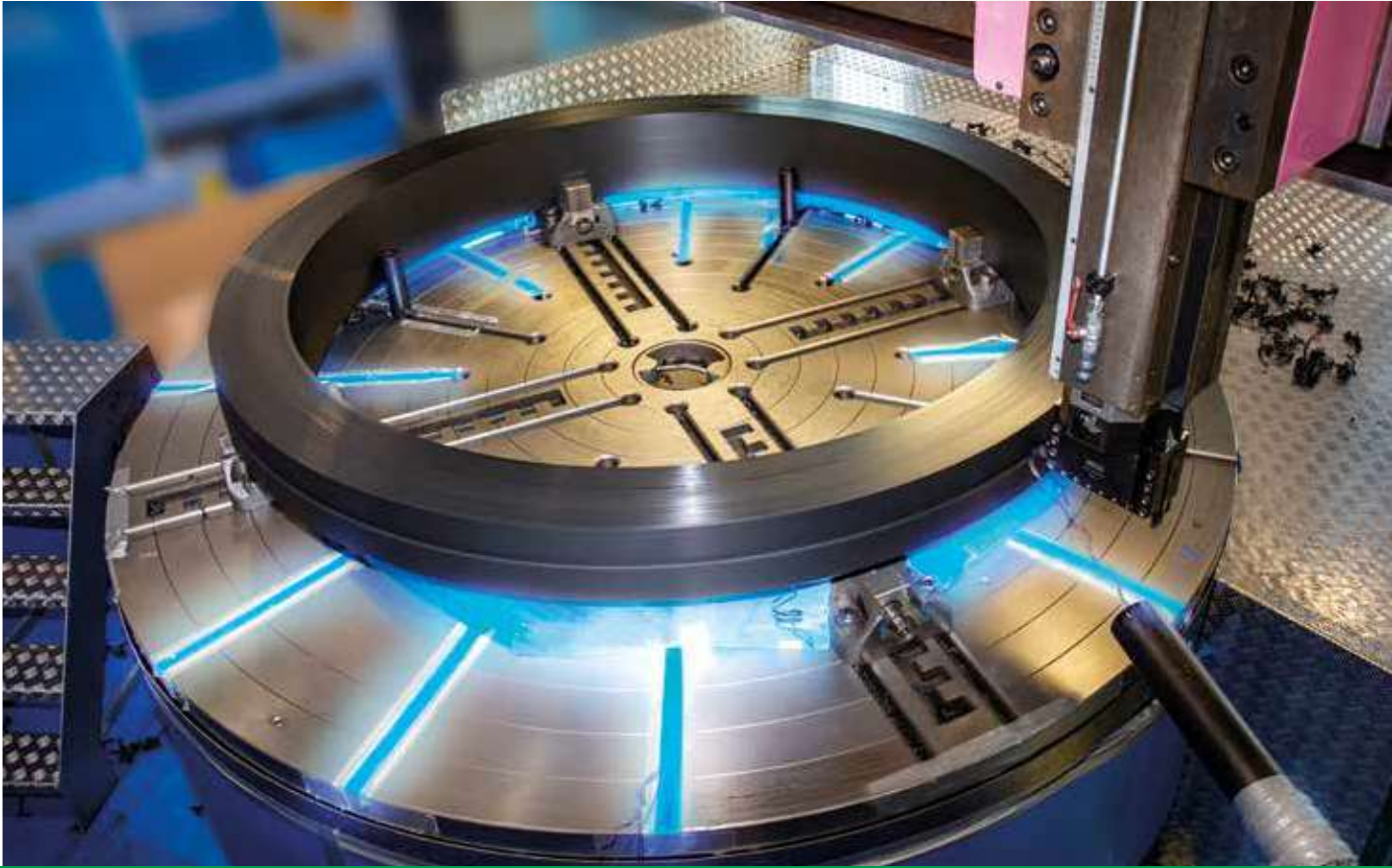



Proven and reliable jointing methods

HEATED PLATE BUTT WELDING

Homogeneous welding connections across the entire wall thickness provides a monolithic system that maintains its full pressure rating without any weak points.

Long-term and proven welding method that is available for all dimensions!

CLEAN, FAST, SAFE

AGRU offers highly automated welding procedures with full documentation and traceability. This welding method requires less labor and keeps you one step ahead of any other fusion technology.

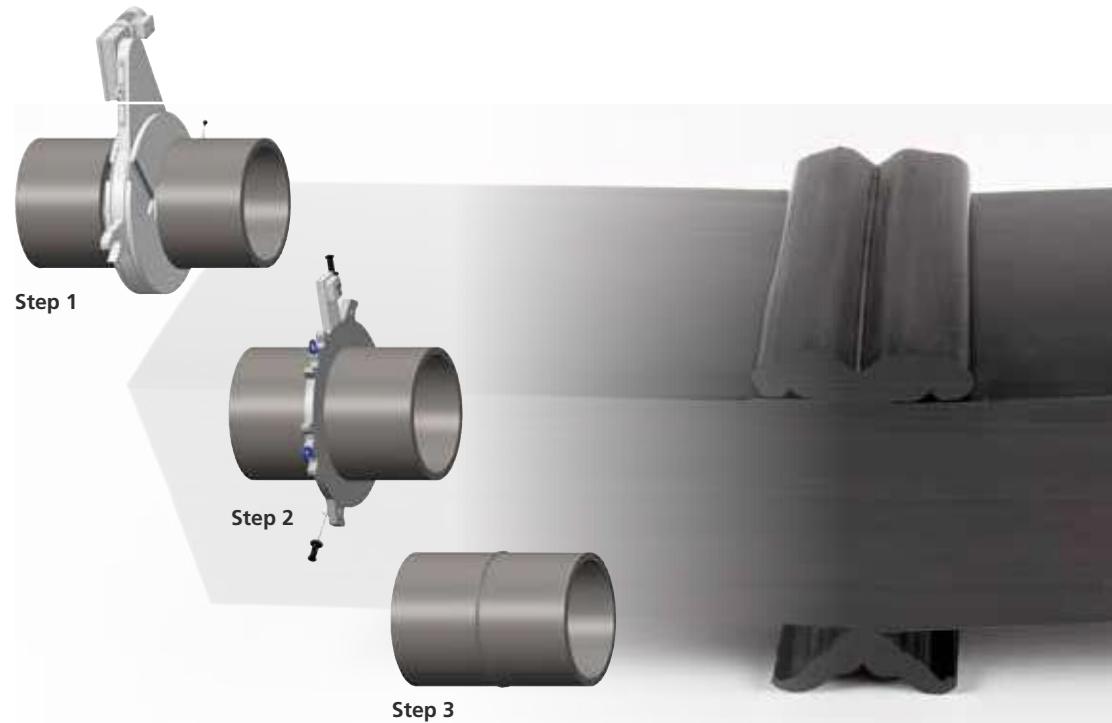

PIPE BRANCHES

The spigot saddle system toplod utilizes a specialized clamping system that offers an efficient and flexible solution to create branches that are electro-fusion welded to existing or new pipelines in on- or offshore locations.

DESIGN-FLEXIBLE, SAFE



FLANGE CONNECTIONS

AGRU supplies mechanical connections that enable detachable transitions to buildings and/or other pipe materials.

PROJECT OPTIMIZED; DETACHABLE, SAFE



Smart logistical solutions by AGRU!

CONTAINER
TRANSPORT



FLAT-RACK TRANSPORT



BREAK-BULK SHIPMENT



CONTAINER TRANSPORT



FLAT-RACK TRANSPORT



BREAK-BULK TRANSPORT



TOWING TRANSPORT



Logistics on demand



PIPE SPOOL PREPARATION



ONSHORE PIPE STRING PREPARATION



WATERFRONT PIPE STRING PREPARATION

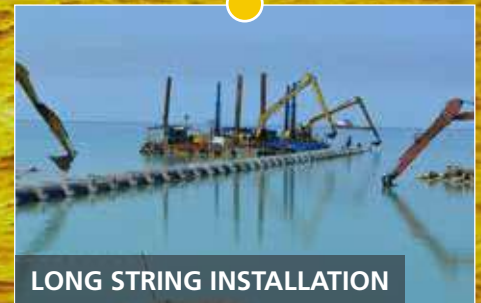

LONG STRING INSTALLATION



AGRU XXL PIPES on the seven seas!

AGRU SUPPLIES PIPE STRINGS UP TO 600 M LENGTH TO SITE LOCATIONS ANYWHERE IN THE WORLD

One stop shop



**SITE BUTT WELDING
EQUIPMENT FOR PIPES
AND FITTINGS UP TO
OD 3500 MM**



**TRANSITIONS TO
BUILDINGS AND OTHER
PIPE MATERIALS**



**PROJECT-SPECIFIC
CHLORINATION SYSTEMS
TO PREVENT BIO-FOULING ON
INTAKE PIPELINES**



**FLANGE CONNECTIONS IN
VARIOUS CONFIGURATIONS**



**CONCRETE PROTECTION
LINING TO PREVENT
CONCRETE DETERIORATION ON
INTAKE/DISCHARGE CHAMBERS**

Offshore float and sink installation, made easy by the AGRU PE 100(-RC) Piping Systems

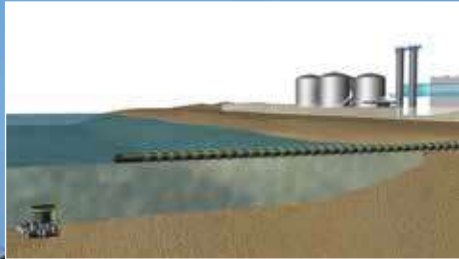

THE FLOATING PE 100(-RC) PIPE IS PULLED INTO THE WATER AND PLACED TO ITS FINAL POSITION

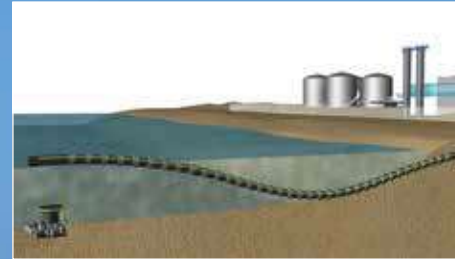

VALVES ARE OPENED AND WATER FLOWS INTO THE PIPE - CONTROLLED SINKING PROCESS IS PROGRESSING

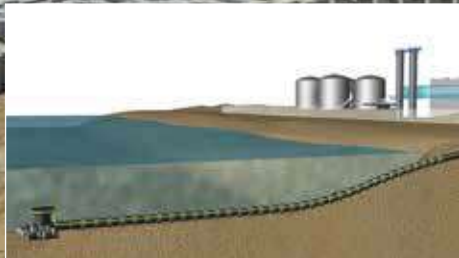

THE PIPE IS CONNECTED TO THE INTAKE STRUCTURE ON THE OCEAN GROUND

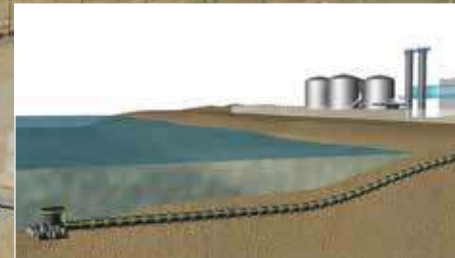

THE PIPE IS COVERED BY BACK-FILL MATERIAL TO PROTECT IT AND TO KEEP IT IN PLACE



Applications

Onshore



**WASTE WATER /
PROCESS COOLING /
MINING /
AGRICULTURE /
MARICULTURE /
REHABILITATION**

Offshore



**POWER PLANTS /
LNG PROCESS COOLING /
DESALINATION /
PROCESSED WASTE WATER**