

LEISTER

®

EN

SEAMTEK 900 AT 2000 AT



Leister Technologies AG
Galileo-Strasse 10
6056 Kaegiswil/Switzerland

Tel. +41 41 662 74 74
Fax +41 41 662 74 16

leister.com
sales@leister.com

Contents

1. SEAMTEK AT	4
1.1 Using this Manual	4
2. Overview of Important Safety Instructions	5
2.1 Important Safety Instructions	5
2.2 Intended Use	6
2.3 Improper Use	6
2.4 Operating Modes	6
2.5 Specialists and Training	6
3. Technical Data	7
4. Transport and Commissioning	7
4.1 Delivery	7
4.2 Unloading the Machine from the Transport Crate	7
4.3 Transportation on the Customer's Premises	7
4.4 Moving the Machine outside of the Company's Premises	8
4.5 Work Environment	8
4.5.1 <i>Welding Vapors</i>	8
4.5.2 <i>Extraction</i>	8
4.6 Workplace and Workplace Environment	9
4.7 Securely Positioning the Machine	10
4.8 Commissioning the Machine	10
4.8.1 <i>Power Supply</i>	10
4.9 Connecting the Compressed-Air Supply	11
5. Your SEAMTEK AT	11
5.1 Type Plate and Identification	11
5.2 Scope of Delivery (standard model in transport box)	11
6. Overview of Machine Elements	12
6.1 Front View	12
6.2 Back View	13
6.3 Outlets	13
6.4 Optional Accessories	13
6.4.1 <i>Sidearm (not available for the SEAMTEK 2000 AT)</i>	13
6.4.2 <i>Quickarm</i>	14
6.4.3 <i>Tape Delivery System</i>	14
7. Operation and Operating Elements	14
7.1 Welding Nozzle	14
7.1.1 <i>Adjusting the Position of the Welding Nozzle</i>	14
7.1.2 <i>Welding Nozzle Position and Heat Input</i>	15
7.1.3 <i>Changing the Welding Nozzle</i>	16
7.1.4 <i>Low-Flow</i>	16
7.1.5 <i>Risk of Burning</i>	16
7.1.6 <i>Air Outlet</i>	17
7.2 Touch Panel Operating Unit	17
7.3 Emergency Stop Push-Button	17
7.4 Emergency Stop Switch	18
7.5 USB Connection	18
7.6 Main Switch	18
7.7 Feet	19
7.8 Pedal Unit	19
7.9 3 bar Pressure Reducing Valve	19

7.10	Welding Arm Options (P, S, Q), Arm Replacement.....	20
7.10.1	<i>Changing the Arm</i>	20
7.10.2	<i>Pedestal</i>	20
7.10.3	<i>Quickarm</i>	21
7.10.4	<i>Sidearm (not available for the SEAMTEK 2000 AT)</i>	21
7.11	Transport Rollers.....	22
7.11.1	<i>Changing the Transport Rollers</i>	22
7.12	Guide Holder.....	23
7.12.1	<i>Mounting and Adjusting the Guide</i>	24
8.	The SEAMTEK AT Control Panel.....	24
8.1	Start screen.....	24
8.2	Home.....	24
8.3	Tab for Changing Views.....	25
8.4	Welding parameters.....	26
8.5	Periphery.....	27
8.6	User.....	28
8.7	Machine Settings.....	30
8.8	Formulas.....	31
8.9	Test Mode.....	32
8.10	Add-Ons Screen.....	33
8.11	Information.....	34
8.12	Setting the date/time.....	34
9.	Welding Sequence and Tips.....	35
9.1	Welding Sequence.....	35
9.2	Tips for a Better Weld Result.....	35
10.	SEAMTEK AT Warning and Error Messages.....	36
10.1	Error Levels.....	36
10.2	Error List.....	36
11.	Frequently Asked Questions.....	39
12.	Maintenance.....	40
12.1	Machine Fault.....	47
13.	Accessories.....	47
14.	Add-ons.....	47
14.1	Monitoring.....	47
14.1.1	<i>Monitoring the Welding Parameters</i>	48
14.1.2	<i>Temperature</i>	48
14.1.3	<i>Air Volume</i>	48
14.1.4	<i>Operating Hours Counter</i>	49
15.	Service and Repair.....	49
16.	Training Course.....	49
17.	Warranty.....	49
18.	Declaration of Conformity.....	50
19.	Disposal.....	50
20.	Quick Reference Guide.....	50
20.1	Switching on/Starting.....	50
20.2	Switching Off.....	50
21.	Appendix.....	51

We would like to congratulate you on having purchased a SEAMTEK AT!

You have chosen first-class hot-air welding device.

It was developed and produced in accordance with the latest advances in the plastics-processing industry. The device has been manufactured using premium-quality materials.



Read through the operating instructions before commissioning.

Always store these operating instructions at the device.

Do not pass the device on to other personnel without the operating instructions.

Leister SEAMTEK AT Automatic welder

Two versions of the SEAMTEK AT are available. The SEAMTEK 900 AT with 900 mm working area and the 2000 AT with 2000 mm working area. Unless otherwise noted, all function descriptions, instructions, warnings, cautions and symbols apply for both versions. The illustrations are based on the 900 AT, the dimensions may differ for the 2000 AT. In the following, the abbreviation SEAMTEK AT refers to both versions.

1. SEAMTEK AT

Thank you for selecting the world's best hot-air rotation welding device. The SEAMTEK AT is a computer-controlled hot-air welding device that is used for joining laminated industrial textiles, e.g., polyvinyl chloride (PVC), polyurethane (PU), polyethylene (PE), and polypropylene (PP). Today, these are used for a multitude of important and interesting products, including 3D applications, tents, tarpaulins, inflatable objects, geomembranes, truck tarpaulins, coverings for the agricultural sector, fishing equipment, protective clothing, protective covers, pipes, synthetic leather, and lots more.

1.1 Using this Manual

This document describes how to assemble and operate the SEAMTEK AT. The device is manufactured by Leister Technologies AG in Kägiswil, Switzerland. It describes the setup, installation, operating sequences, nature, and tasks of the various modules that are available for using your SEAMTEK AT. This documentation also comprises a list outlining troubleshooting tips as well as warranty information, and a table of contents. This manual is intended to ensure that the SEAMTEK AT is installed and operated in a proper manner. Please read through all of the sections in this manual carefully before using your SEAMTEK AT.

This version invalidates any versions created at an earlier date. It will in turn also lose its validity as manuals with later dates appear.

Leister Technologies AG makes every effort to ensure that the information contained in this manual is complete and exact.

No guarantee, neither concrete nor implied, is however provided, nor is any liability assumed for the use of this information with respect to either its completeness or accuracy.

This manual may be updated from time to time without prior notice. The latest version of all operating instructions published by Leister Technologies AG can be obtained by authorized users upon request to Leister Technologies AG.

2. Overview of Important Safety Instructions

2.1 Important Safety Instructions

Warning



Danger to life due to dangerous voltage

Before opening the switch cabinet, the device must be disconnected from the power supply at all poles. (Disconnect the power plug.) Live components and connections may be exposed in the process. Connect the device to an **outlet with a protective conductor**. Any interruption of the protective conductor inside or outside of the device is dangerous. Only use extension cables with protective conductors. Protect the device **from moisture and wet conditions**.



Danger of fire caused by improper use of the welding machine (e.g., material overheating) and particularly in the vicinity of combustible materials!



Risk of burning!

Do not touch heating element tube and nozzle when they are hot. Do not wear any jewelry or watches, particularly on the hands, arms, and fingers. The device should always be allowed to cool down first.



Danger of poisoning! Gases are released during the processing of plastics, lacquers or similar materials that could be aggressive or toxic. Avoid breathing in vapors, even if they seem to be harmless. Make sure the workplace is well-ventilated at all times or wear a breathing mask.



Danger of crushing! When the nozzle is retracted, there is a risk of crushing because of pneumatically moving parts. Make sure that no part of the body are trapped when changing the arms.



Risk of entanglement!

Do not reach between moving parts, e.g., transport rollers, in order to avoid any risk of objects being pulled in.



Danger: At least two people are needed to safely remove the machine from the wooden crate. Make sure that the machine does not topple over.

Caution



The **nominal voltage** specified on the device must match the local **supply voltage**. If the supply voltage fails, the main switch and the drive must be switched off.



To use the device, a **FI safety switch** is **required** to protect the personnel working at the site where the device is being used.



The device **must be monitored continuously during operation!** Waste heat can come into contact with flammable materials that are not in view.

Device may be operated only by **trained specialists** or under their supervision. Children are not permitted to operate the equipment under any circumstances.



When **working on the open system**, do not wear such articles of clothing as scarves, shawls, or neckties. Tie up long hair or protect it by wearing headgear.



Depending on the configuration of the machine (nozzle width, nozzle setting, air volume) and the welding material used, the machine may reach a critical volume level. You and any people in the vicinity must wear suitable hearing protection in the course of this.

2.2 Intended Use

The SEAMTEK AT has been designed for the professional welding of thermoplastics.

Use only Original Leister spare parts and accessories since otherwise, no warranty or guarantee claims can be asserted.

2.3 Improper Use

Any other use or any use beyond that described is deemed as improper use.

2.4 Operating Modes

- **Normal operation:** In this mode, the machine welds material. The machine can be used in manual, automatic, and semi-automatic operation.
- **Setup operation:** Everything must be set up first in order to prepare the machine for normal operation. This is done in the setup operation mode.
- **Maintenance/Service/Installation:** In this mode, the machine is not in operation. The machine must be disconnected from the power and pneumatic supply before performing the relevant tasks.

2.5 Specialists and Training

- **Operators:** The personnel responsible for setting up, operating, and cleaning the machine are defined as operators. These personnel are obliged to carefully read the operating instructions and to observe the safety instructions contained therein. In addition, the operators are instructed by the administrators on how to operate the machine.
- **Administrator:** The personnel responsible for the repair, maintenance, installation, and adjustment of the machine are defined as administrators. These personnel are trained extensively by Leister Technologies AG or by a representative instructed to do so. These personnel are obliged to carefully read the operating instructions and to observe the safety instructions contained therein.
- **Specialists:** Responsible for correctly connecting the machine. The specialists must have received electronic or electrical training. These personnel are obliged to carefully read the operating instructions and to observe the safety instructions contained therein.

3. Technical Data

		SEAMTEK 900 AT	SEAMTEK 2000 AT
Nominal voltage	V~	230/240 (US)	
Frequency	Hz	50/60 (US)	
Nominal current	A	19	
Nominal voltage	W	4500	
Temperature	°C	120 – 700	
Maximum temperature	°C	700	
Airflow range	l/min	80 – 170	
Drive speed	m/min	0 – 30	
Electronics		PC panel with PLC	
Blowers		Volumetric flow controlled Rotary vane pump	
Maximum roller clamping pressure	N	600	
Weld seam width	mm	8 – 64	
Emission level	LpA (dB)	≈ 78	
Dimensions of machine (L × W × H)	mm	1500 × 702 × 1500	2650 × 702 × 1500
Dimensions of packaging (L × W × H)	mm	1760 × 926 × 1536	2936 × 926 × 1536
Weight of machine	kg	approx. 238 kg (basic version) approx. 268 kg (fully equipped)	approx. 403 kg (basic version)
Weight of packaging	kg	145	243
Mark of conformity		CE	
Protection Class I			

Subject to change without prior notice.

4. Transport and Commissioning

4.1 Delivery



Do not use a crane or other similar equipment to lift the machine.

The SEAMTEK AT is delivered packaged and well-protected in a transport crate. When moving the machine in the transport crate, pay attention to the symbols for the center of gravity.

4.2 Unloading the Machine from the Transport Crate



Danger: At least two people are needed to safely remove the machine from the wooden crate. Make sure that the machine does not topple over.

Turn the **feet (6)** upward until the stop to ensure maximum floor clearance.

To safely unload the machine from the transport crate, we recommend consulting the video tutorial available. Please ask your distribution partner for this.

1. Remove the front cover of the wooden crate. This cover can also be used as a ramp.
2. Position the front cover as a ramp in front of the wooden crate and secure the ramp.
3. Then detach all wooden transport securing devices.
4. Turn all four **feet (6)** upward as far as possible.
5. Using the moving wheel, turn the machine outwards.
6. Slowly move the machine out of the wooden crate. While doing so, make sure that the machine cannot topple over.

4.3 Transportation on the Customer's Premises



Danger: Allow the machine to sufficiently cool down prior to being transported.
(See cool-down mode, Chapter 8.5)

To move the machine to the desired location on the respective company's premises, the **feet (6)** must be turned upward as far as possible until there is no longer any contact with the floor and the machine rests on the floor with all three wheels.

4.4 Moving the Machine outside of the Company's Premises

Only move the well-secured machine in the transport box provided for this purpose.

4.5 Work Environment



Danger: Never use the SEAMTEK AT in readily inflammable surroundings and maintain a sufficient distance from combustible materials or explosive gases at all times!
The hot-air welding machine must only be used in well-ventilated rooms.

- Do not place the machine in the vicinity of sources that cause significant vibrations; this may be other machines, in the vicinity of the road, or other similar entities.
- To ensure access around the machine, an unobstructed working area of at least 1 m must be available around the machine.
- Depending on the function, the **AHAM (13)** swings back and forth. Ensure that persons and objects maintain an adequate distance.

4.5.1 Welding Vapors



Danger: Welding certain materials can result in the formation of poisonous vapors. You must therefore ensure that enclosed rooms are well-ventilated. If this is not possible, the welding vapors must be extracted by suction.

Make sure to use the correct welding parameters. When redetermining the welding parameters, start with a low temperature and increase the temperature until you achieve a good weld result. Make sure that the weld materials are not burnt in order to reduce the welding vapors produced. As an accessory, Leister offers an adapter for the SEAMTEK AT, which can easily be mounted on an external vacuum device. Please ask your distribution partner about this.

4.5.2 Extraction

The vacuum device (Leister accessory 155.410) is supplied without an extraction unit. Therefore, Leister recommends the following unit properties.

Volume flow	(20 °C) 234 m ³ /h	(68 °F) 138 cfm
Hose connection	∅ 90 mm	3.54"

The extracted air can be filtered with an internal filter unit. The internal unit must be equipped with a multi-stage filter combination to filter gases and smoke.

If the extracted air is not filtered internally, the exhaust gases can also be conducted out of the building. We recommend the Leister Airpack (119.358) as an external blow-off unit. Local laws and regulations must be observed for this purpose.

4.6 Workplace and Workplace Environment

The SEAMTEK AT has rollers on its frame, which allow the machine to be moved easily to a different location. Please make sure that the required space for the machine is maintained, and that the adjustable feet are locked into place whenever the machine has been moved.

The working area may exceed the marked area.

Pay particular attention to the safety distance. A distance of 200 mm must be maintained, as the hot air nozzle unit swings outward. Warm air is blown out of the back of the machine. The distance to the wall must therefore be observed.

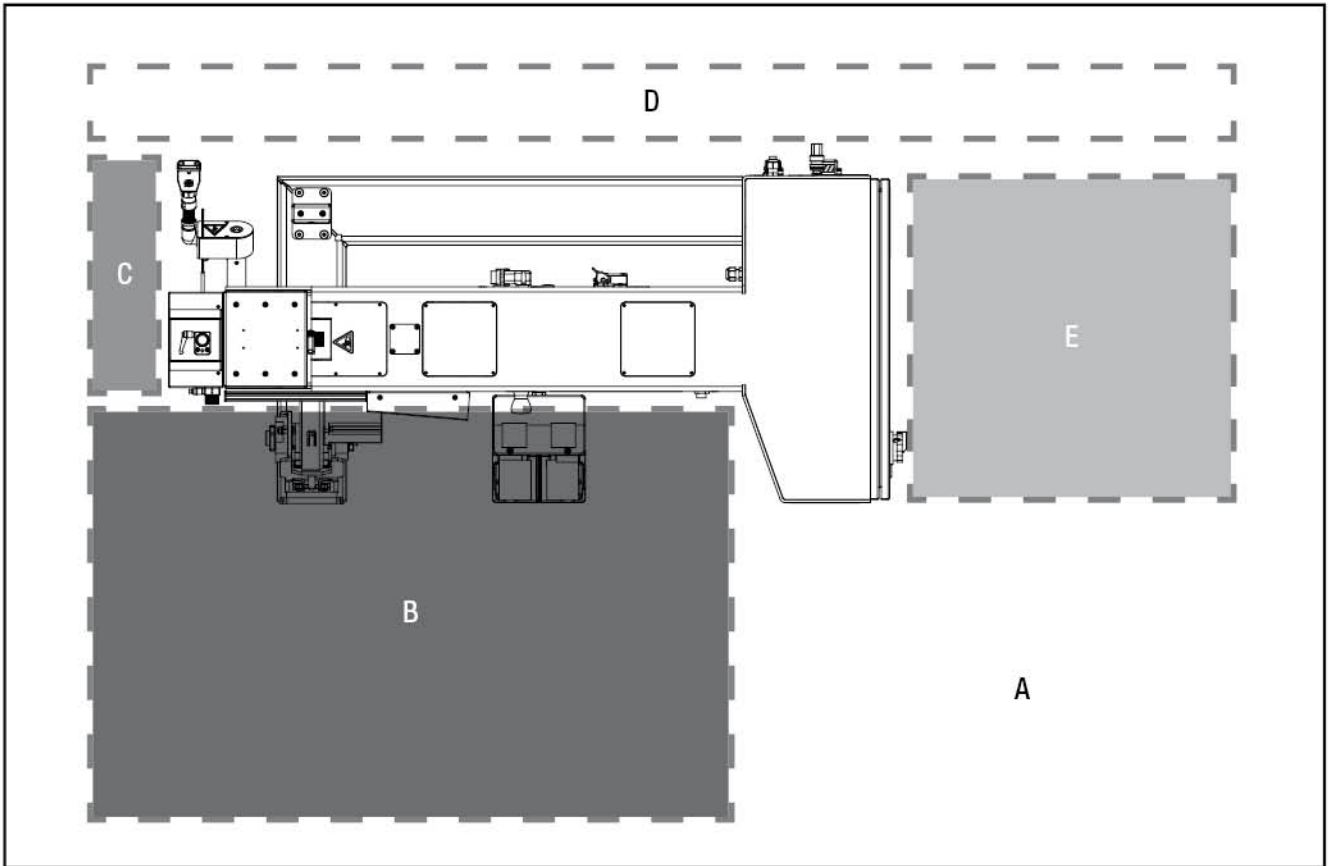

			SEAMTEK 900 AT	SEAMTEK 2000 AT
A	Required space for the machine	mm	2380 × 1530	3530 × 1530
B	Working area	mm	1350 × 840	2500 × 840
C	Safety distance	mm	540 × 200	540 × 200
D	Distance to the wall	mm	2380 × 250	3530 × 250
E	Required space for the service doors	mm	700 × 670	700 × 670

The machine must only be operated at an altitude of up to max. 2,000 m above sea level. We cannot guarantee that the machine will function properly if it is used at a higher altitude.

Furthermore, ensure that the machine is only operated in conditions with a maximum humidity of 95% and a maximum temperature of 45 °C. Individual components of the machine may no longer function properly if it is still used above these limits.

The operator should work in front of the machine on a height-adjustable chair. This allows the operating personnel to correctly view the welding point and therefore prevents postural problems.



The machine must always be used with gloves to protect against the hot temperatures.

4.7 Securely Positioning the Machine

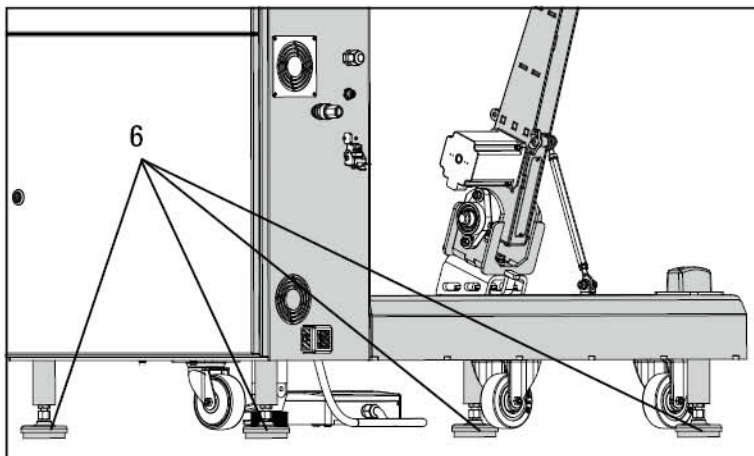

The machine must be placed on an even substrate. Turn all four **feet (6)** downward (anticlockwise direction of rotation) until the machine equally rests on all **feet (6)** and is suitably and securely positioned. Use a spirit level to align the machine.

4.8 Commissioning the Machine

Check the machine for damage before commissioning.

4.8.1 Power Supply

Connection Plug

The machine must be connected to a residual current circuit breaker. Residual current protection devices prevent dangerously high ground currents and help reduce the number of life-threatening electrical accidents.

Power Supply Connector Plug

The SEAMTEK AT is supplied without a connector plug. Connect a plug that guarantees the specifications of the machine and complies with all statutory requirements specified in the respective country.

The following specifications regarding the current source and the connector plug must be observed.

Nominal voltage	V	230–240
Frequency	Hz	50/60
Nominal current	A	20

Power supply cord and extension cable

- The nominal voltage specified on the device must match the supply voltage.
- The cable for the **power connection for the machine (22)** must be freely movable and must not impede users or third parties during work (tripping hazard) see picture 6.2.
- The extension cables must be permitted for the utilization site and be marked accordingly. Take into account the necessary minimum cross-section for extension cables as required.

Connection cable

		International (230 V): Function	USA (240 V): Function
Wire colors Connection cable Machine	brown	L1 (230V AC)	L1 (120V AC)
	light blue	N	L2 (120V AC)
	yellow/green	PE	PE

4.9 Connecting the Compressed-Air Supply

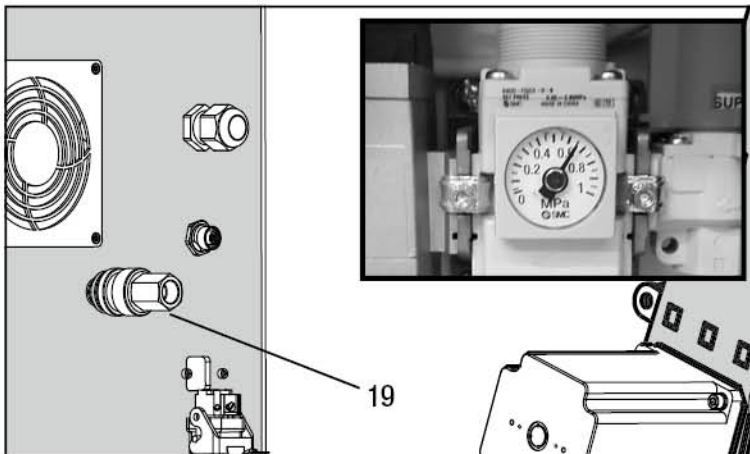

Connect a suitable compressed air cable to the **compressed air connection (19)** and connect the cable to a source that supplies a minimum of 8 bar. Set the **compressed air controller** to 6.5 bar.

The Seamtek is supplied with a quick coupling (19) but not a hose connector. Use an in-house hose connector with an external thread of R/Rc 1/4". Screw this connector into the internal thread of the quick coupling (19). Connect the in-house hose to the hose connector. Now connect the hose to a compressed air source that supplies a minimum of 6.5 bar (94 psi) and a maximum of 10 bar (145 psi). Inspect the pressure at the pressure gage within the pneumatic-system cabinet (26). Adjust the pressure with the hand wheel as necessary.

5. Your SEAMTEK AT

5.1 Type Plate and Identification



The type designation and serial number are specified on the type plate on your device. Transfer this information to your operating instructions; in the event of any inquiries to our representatives or authorized Leister service center, please always refer to this information.

Article no.:

Serial no.:

5.2 Scope of Delivery (standard model in transport box)

1 x Seamtek AT	2 x 25 mm steel rollers, mounted
1 x pedestal, mounted	1 x connection cable (without plug)
1 x quickarm, optionally mounted (optional accessory)	2 x key for switch cabinet
1 x sidearm, optionally mounted (optional accessory)	1 x operating manual
1 x tape delivery system, optionally mounted (optional accessory)	1 x wiring diagram
1 x 25 mm nozzle, mounted	

6. Overview of Machine Elements

6.1 Front View

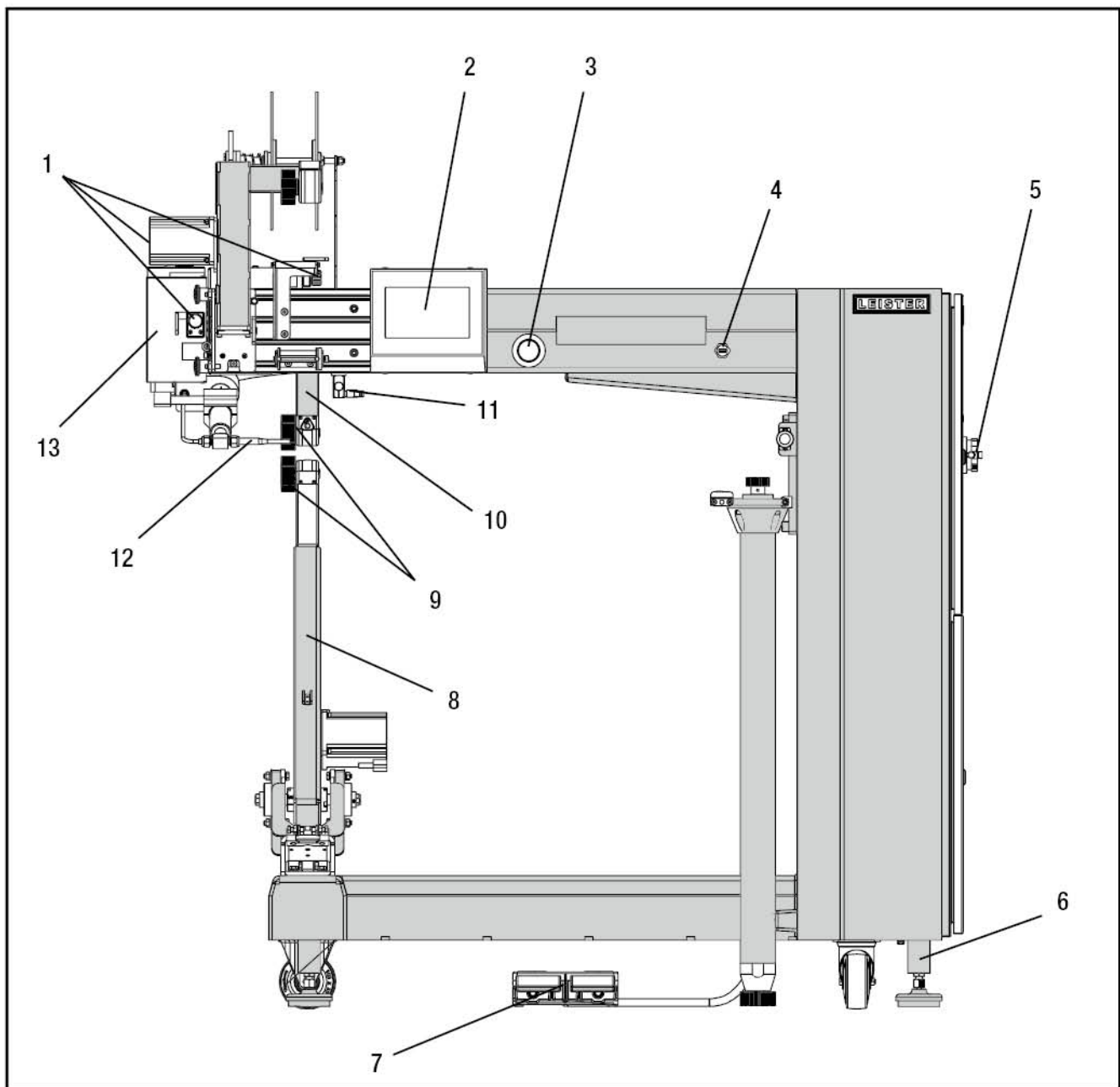

- | | |
|---|---|
| 1. Adjusting screws for nozzle position (Chapter 7.1) | 8. Welding arm (pedestal) (Chapter 7.8) |
| 2. Touch panel (Chapter 7.2) | 9. Transport rollers (Chapter 7.9) |
| 3. Emergency stop button (Chapter 7.3) | 10. Upper pressure roller (upper wheel module, UWM) |
| 4. USB connection (Chapter 7.4) | 11. Guide holder (Chapter 7.10) |
| 5. Main switch (Chapter 7.5) | 12. Welding nozzle (Chapter 7.1) |
| 6. Feet (Chapter 7.6) | 13. Adjustable hot air module |
| 7. Pedal unit (Chapter 7.7) | |

6.2 Back View

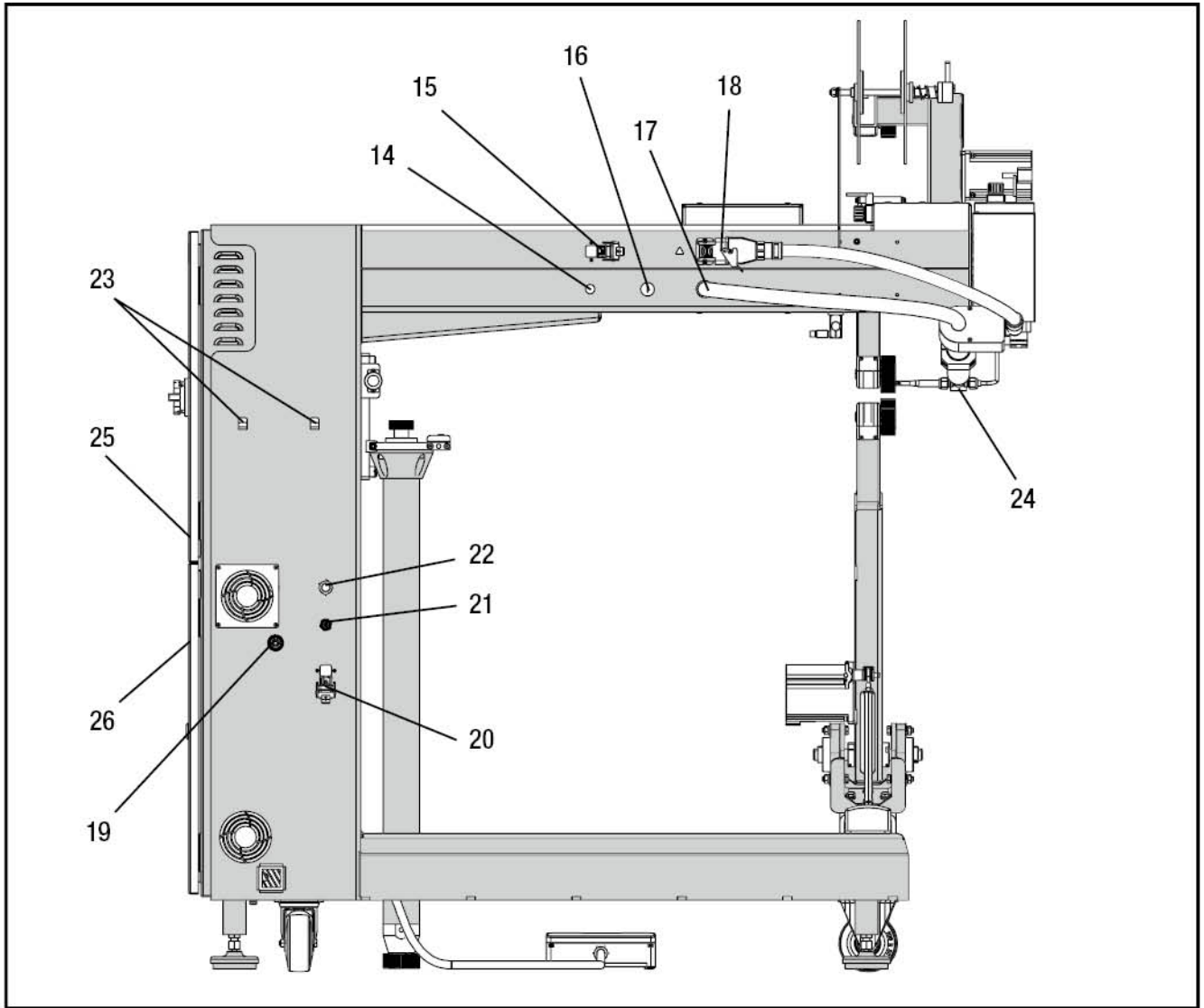

- | | | |
|---|--|---|
| 14. Ethernet output for accessory A | 19. Compressed air connection for machine supply | 23. Suspension equipment for pedal |
| 15. Electrical connection for accessory A | 20. Electrical connection for accessory B | 24. Heating element for protective pipe |
| 16. Compressed air connection for accessory A | 21. Ethernet output for accessory B | 25. Switch cabinet |
| 17. Air line to heating element | 22. Power connection for machine | 26. Pneumatic cabinet |
| 18. Electrical connection for heating element | | |

6.3 Outlets

The outlets (15 and 20) on the machine are only approved for use with Leister accessories. The electrical connection is supplied with mains voltage. Leister is not liable for any non-approved use.

6.4 Optional Accessories

6.4.1 Sidearm (not available for the SEAMTEK 2000 AT)

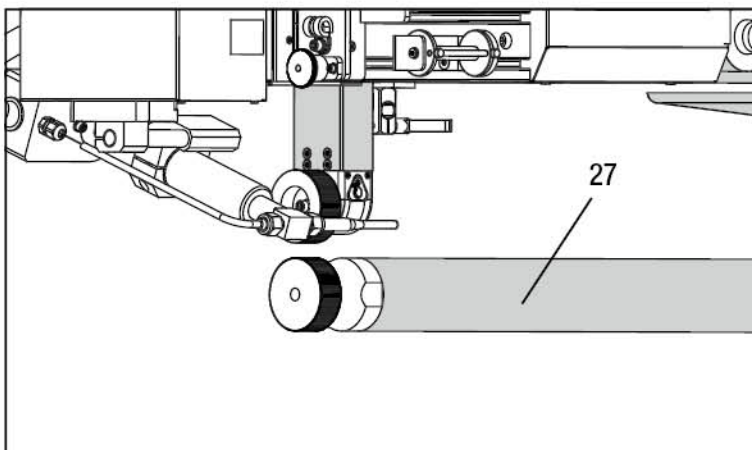

This additional welding arm is particularly suitable for welding on covers for inflatable pipes and bags.

The machine can be equipped with the sidearm (27) in two different ways. The sidearm (27) is either fitted to the machine directly by Leister or mounted on the machine afterwards by the customer.

6.4.2 Quickarm

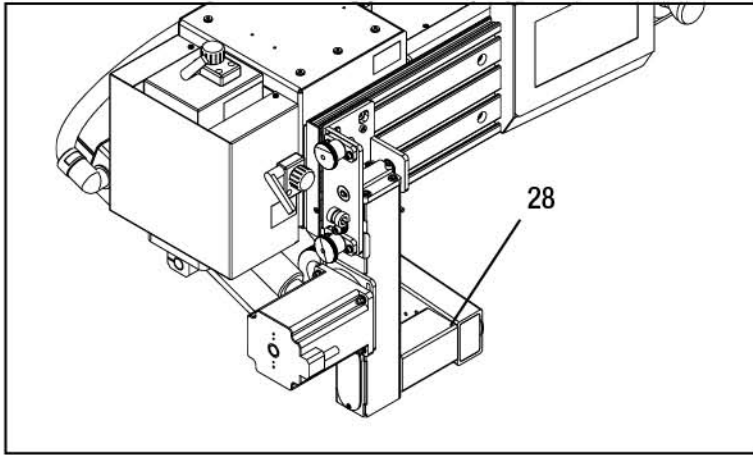

This accessory enables the production of endless pipes and hoses.

The machine can be equipped with the **quickarm (28)** in two different ways. The **quickarm (28)** is either fitted to the machine directly by Leister or mounted on the machine afterwards by the customer.

6.4.3 Tape Delivery System

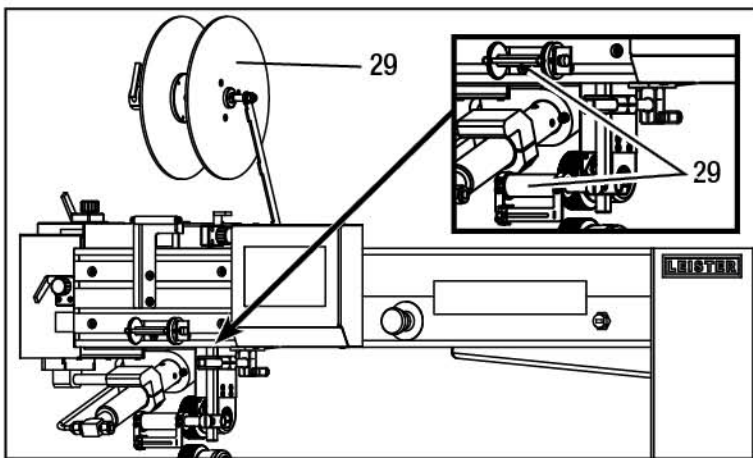

The **tape delivery system (29)** is suitable for supplying tape during the joining process. The system is primarily used for sealing (taping) seams and gluing (bonding) non-weldable materials.

The machine can be equipped with the tape delivery system in two different ways. The tape delivery system is either fitted to the machine directly by Leister or mounted on the machine afterwards by the customer.

7. Operation and Operating Elements

7.1 Welding Nozzle

7.1.1 Adjusting the Position of the Welding Nozzle



Before making any adjustments, screw the nozzle as far as possible from the transport rollers (9) in order to prevent collisions.



Danger of crushing! When the nozzle is retracted, there is a risk of crushing because of pneumatically moving parts.



Depending on the configuration of the machine (nozzle width, nozzle setting, air volume) and the welding material used, the machine may reach a critical volume level. You and any people in the vicinity must wear suitable hearing protection in the course of this.



Now set the **welding nozzle (12)** to the welding position under the “welding conditions” tab (set everything to “Automatic” mode). Each time an arm, the **transport rollers (9)**, or **welding nozzle (12)** are changed, the position of the nozzle must be subsequently readjusted. Before readjusting the **welding nozzle (12)**, remove the mounted guide, where applicable. Turn the **welding nozzle (12)** in the starting position as far as possible away from the machine to ensure that the **welding nozzle (12)** does not collide with the machine when swiveling into position.

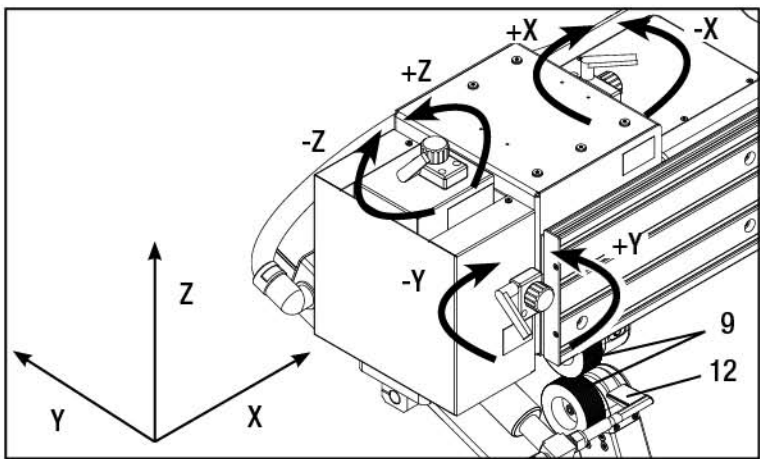

Slightly tighten the clamping lever for the positioning screws once the **welding nozzle (12)** has been adjusted. Initiate Start Weld to check that the **welding nozzle (12)** does not come into contact with anything when swiveling in and out. Adjust the angle of the nozzle as necessary.

Z Direction

Turn the **adjusting screw (Z)** in direction (+Z), to position the **welding nozzle (12)** higher and in direction (-Z), to position the nozzle lower. Lock the **adjusting screw (Z)** in place with the clamping lever.

Y Direction

Turn the **adjusting screw (Y)** in direction (-Y), to move the **welding nozzle (12)** away from the rollers and in direction (+Y), to move the nozzle in the direction of the rollers. Lock the **adjusting screw (Y)** in place with the clamping lever.

X Direction

Turn the adjusting screw in direction (-X), to move the **welding nozzle (12)** to the left and in direction (+X), to move the nozzle to the right. Lock the **adjusting screw (X)** in place with the clamping lever.

7.1.2 Welding Nozzle Position and Heat Input

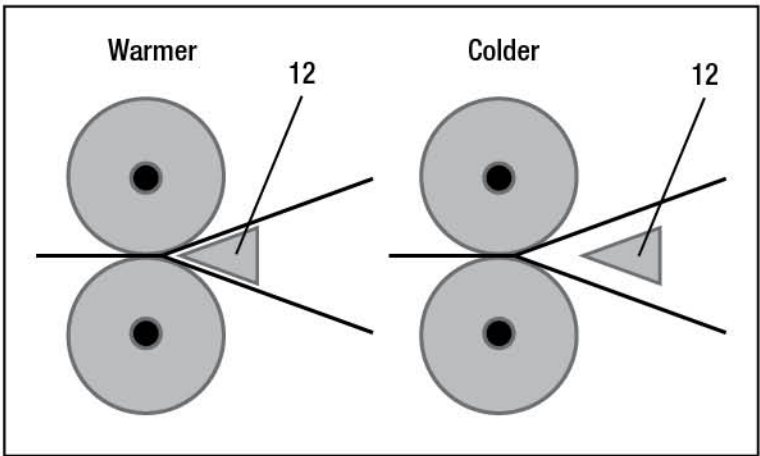

The closer the **welding nozzle (12)** is to the transport rollers, the higher the energy entry is in the welding zone, or rather the adjustable welding temperature will be lower for the same weld result.

The **welding nozzle (12)** must be positioned at a sufficient distance from the welding zone to ensure contact-free [no direct contact with the **welding nozzle (12)**] material supply. Adjust the **welding nozzle (12)** such that minimal noise emissions occur.

7.1.3 Changing the Welding Nozzle



Caution: Completely cool the machine with the cool-down mode before changing the **welding nozzle (12)**. The **welding nozzle (12)** may still be hot even following the cool-down mode.

A 25 mm **welding nozzle (12)** is mounted as standard. Nozzles are available in widths from 8–64 mm.

Before mounting a new **welding nozzle (12)**, use adjusting screw (Y) to turn the **welding nozzle (12)** as far as possible away from the machine in direction (-Y). Before changing the **welding nozzle (12)**, allow the machine to completely cool down.

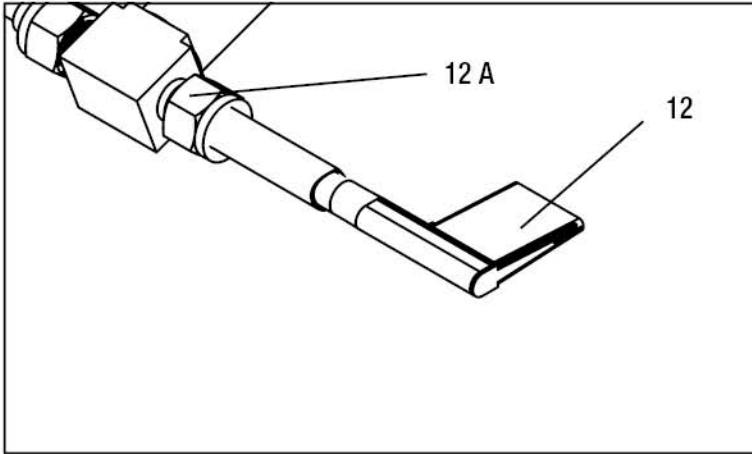

Then detach the **nut (12 A)** with an 11/16 inch open-end wrench. The **welding nozzle (12)** can now be removed. Handle the **welding nozzle (12)** carefully so as not to damage the air output opening. Then mount the desired **welding nozzle (12)** and securely tighten it.

7.1.4 Low-Flow

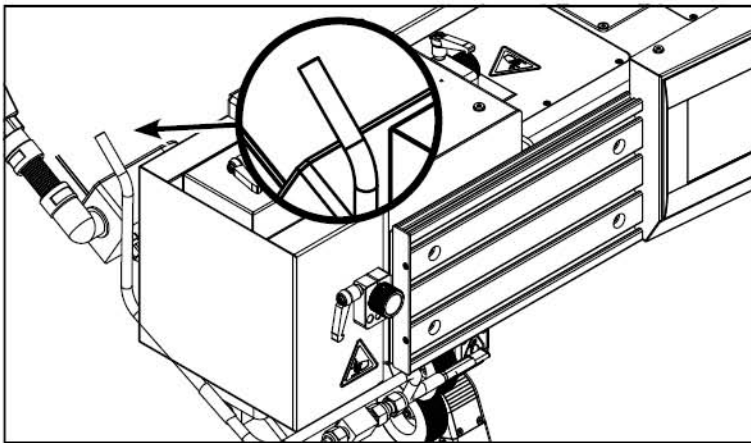

Hot air is discharged through a bypass when low-flow nozzles are used.

Hot air may escape from the end of the bypass in the process. Make sure that no one is in the hazard zone.

7.1.5 Risk of Burning

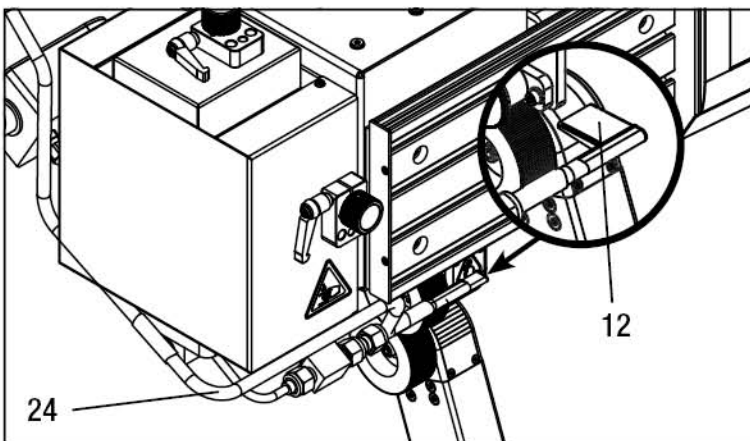

Danger: The **welding nozzle (12)**, heating element pipe, and the **heating element protective pipe (24)** can be very hot during operation. There is a risk of burning when touching these elements. Never touch one of these components while the machine is operating. These elements may still be warm even following the cool-down mode.

The SEAMTEK AT is a hot-air welding machine. Depending on the respective process, some components can become incredibly hot. Always operate the machine with due caution.

7.1.6 Air Outlet

Air from the pump that is not required in the machine is discharged from the machine via a bypass. This is why hot air can escape from the back of the machine. (Refer to the figure for residual air outlet)

In addition, warm air can be blown out of the machine from the cooling air outlet (see figure), which is required to cool the pneumatic cabinet.

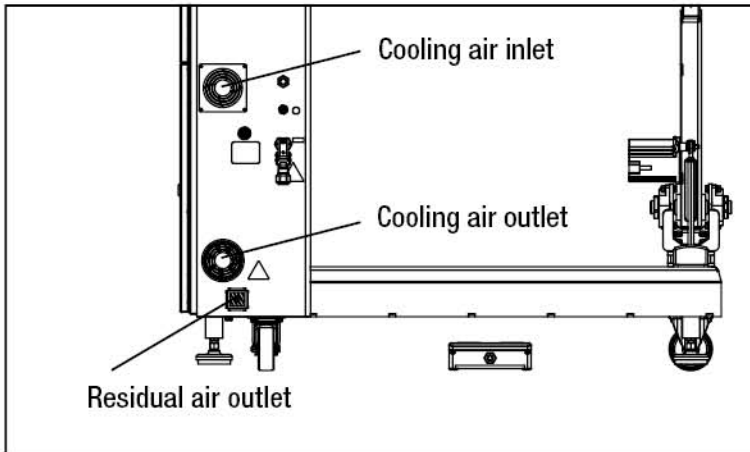

7.2 Touch Panel Operating Unit



Caution: Only use your fingers to operate the touch panel. Do not use non-authorized objects such as pens and tools in order to avoid damaging the **touch panel (2)**.

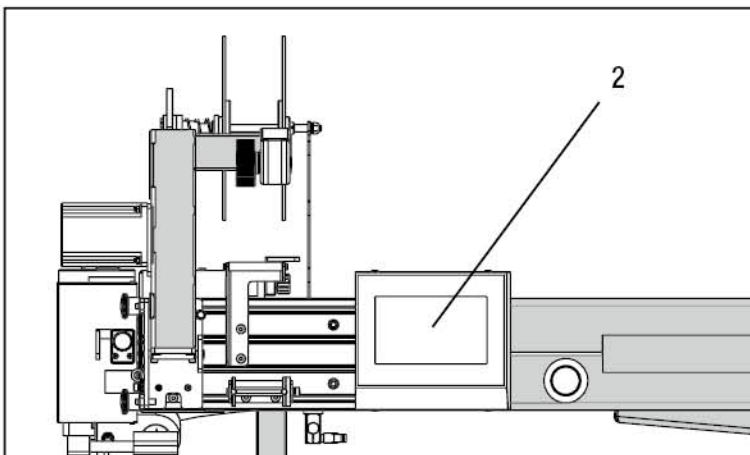

The **touch panel (2)** can be used to see current operating statuses as well as to edit all welding parameters. Before operating the touch panel, carefully read through Chapters 7 and 9.

7.3 Emergency Stop Push-Button



Caution: As the machine does not execute the cool-down mode when the **emergency stop button (3)** has been pressed, the stop button must only be used in emergencies. The service life of the heating element is significantly reduced if it forgoes the cooling-down process.

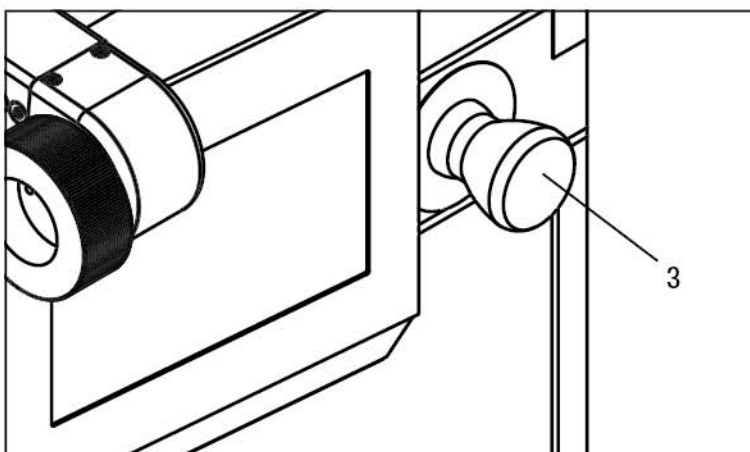

Pressing the **emergency stop button (3)** completely shuts down the machine in an instant.

7.4 Emergency Stop Switch

The following occurs as soon as you press this switch:

1. The machine is disconnected from the power supply. The heating element and the pump are switched off.
Caution: If the emergency stop switch is activated while the heating element is switched on, this can cause considerable damage to the machine. Therefore, make sure that the machine is switched on again as soon as possible, otherwise the heating element can be damaged. As soon as the machine is switched on again, it automatically activates the cooling process. This means that the pump is restarted.
2. The compressed air is disconnected from the main line. The cylinders cannot be used. The pressure is not released in all of the cylinders.
3. The machine is switched off. All the accessory components connected to the machine are also deactivated.

Restarting the machine:

1. The machine can be switched on by turning the emergency stop switch.
2. The machine restarts as soon as the emergency stop switch is released. This enables the power and compressed air supply.
3. The accessories are set to their initial state.

7.5 USB Connection

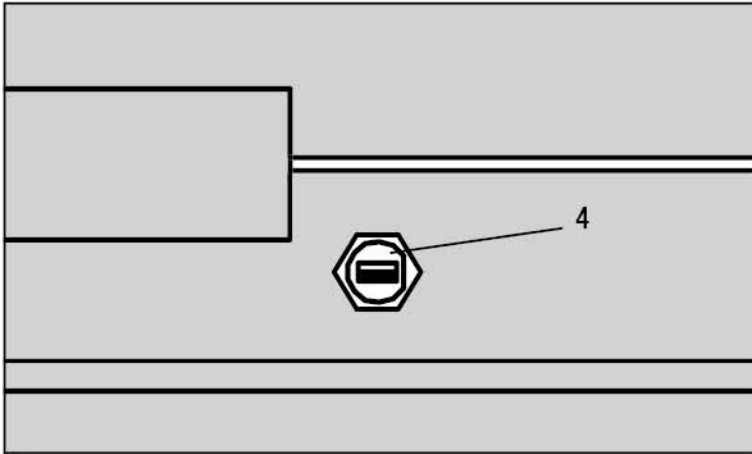

Use the **USB connection (4)**, to externally backup your saved formulas or to use the formulas on several SEAMTEK AT machines at the same time.

7.6 Main Switch



Caution: As the machine does not execute the cool-down mode if it is switched off via the **main switch (5)**, this switch must only be activated following the cool-down process. The service life of the heating element is significantly reduced if it forgoes the cooling-down process.

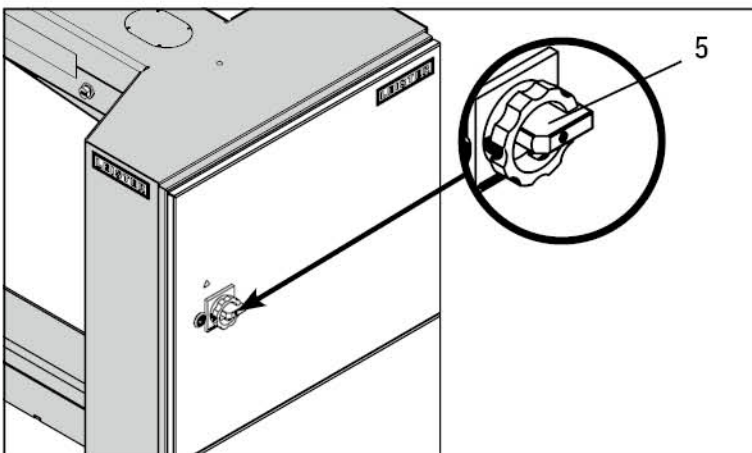

Turn the **main switch (5)**, to start the machine or completely switch off the machine following cool-down mode. Prior to extended interruptions, always switch off the machine using the **main switch (5)**.

7.7 Feet

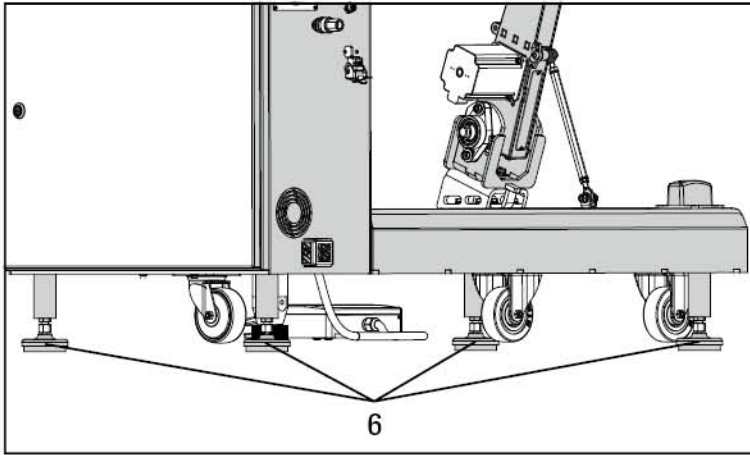

Turn the **feet (6)** clockwise (seen from above), to turn the feet downward and turn the feet anticlockwise, to turn the feet upward. Ensure that the machine is suitably and securely positioned before it is commissioned.

7.8 Pedal Unit

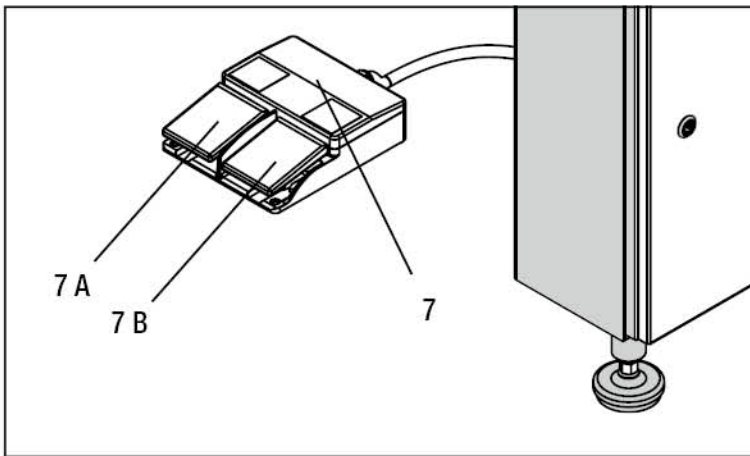

Danger: Take care not to confuse the two **pedals (7 A + 7 B)** of the pedal unit – particularly if you want to position the material and inadvertently start the welding process. This can result in burns to the hands. Orientate yourself at the separating wall between the two **pedals (7 A + 7 B)**.

The **pedal unit (7)** enables you to position the material as both hands remain free as well as to start and stop the welding process. Using the **left-hand pedal (7 A)**, you can lift the upper roller in order to position the material. You can start and stop the welding process with the **right-hand pedal (7 B)**.

7.9 3 bar Pressure Reducing Valve

Compressed air cylinders are used to move the AHAM. For this purpose, a pressure reducing valve has been installed in the pneumatic cabinet. This is preset to max. 3 bar. The reduced pressure helps prevent serious injuries when the AHAM is swiveled in.



Caution: Do not remove the cover sheet.

Do not adjust the pressure. This can lead to injuries when the AHAM is swiveled in. In addition, the machine is also worn down more quickly.

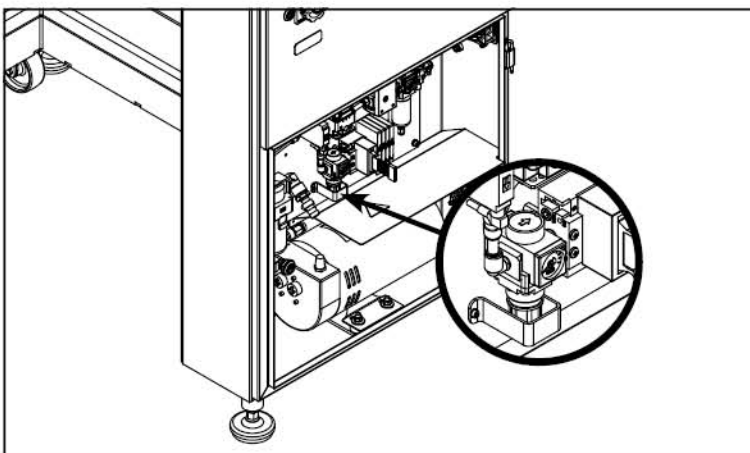

7.10 Welding Arm Options (P, S, Q), Arm Replacement



Caution: To select the active arm, the **motor icon (M)** must be switched off. Make sure that the correct arm is selected to prevent damage to the drive.



Danger of crushing! When the nozzle is retracted, there is a risk of crushing because of pneumatically moving parts. Make sure that no part of the body are trapped when changing the arms.

7.10.1 Changing the Arm

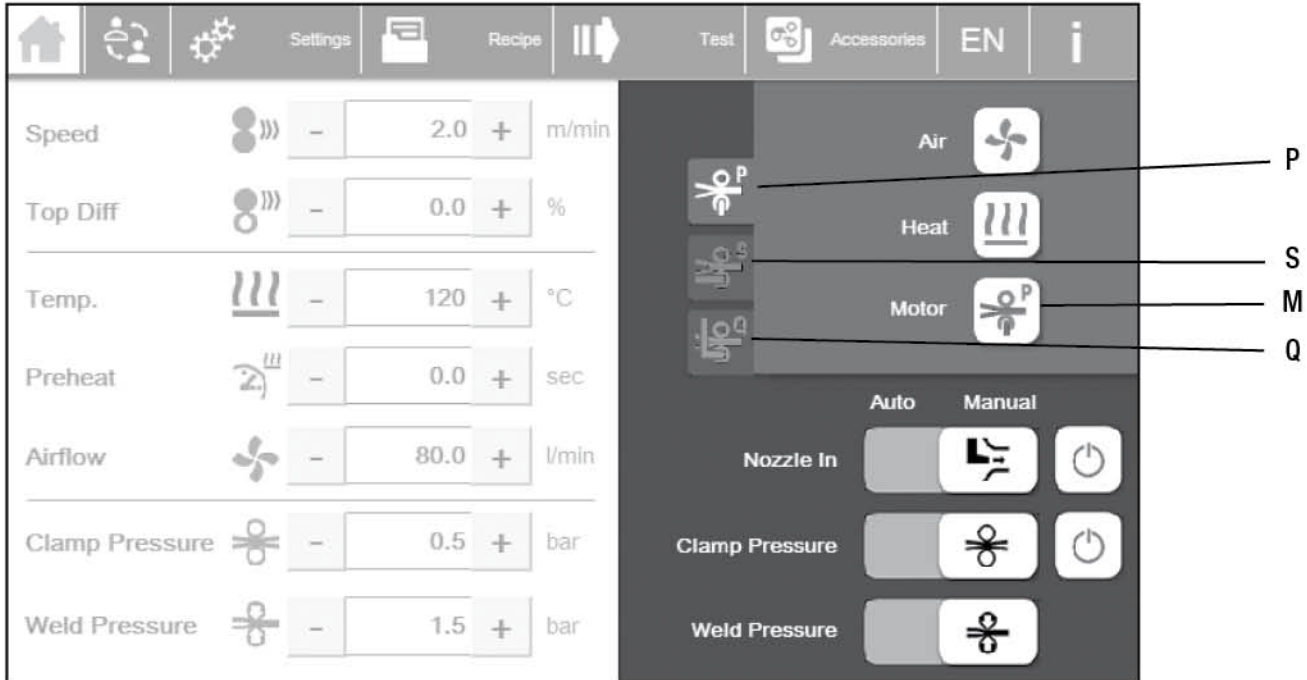

To make replacements between the individual arms, please set all settings to “Manual” and “Off” in advance. The **transport rollers (9)** are now open and the **welding nozzle (12)** is in the starting position.

Switch off the motor and select the arm in which you are replacing the:

Pedestal (P) see Chapter 7.8.2 / **Sidearm (S)** see Chapter 7.8.4 / **Quickarm (Q)** see Chapter 7.8.3

7.10.2 Pedestal



Caution:

Always hold the **pedestal (8)** when you detach the **retaining pin (8 B)**. Then carefully lay the pedestal down. If the pedestal falls downward unchecked, it may sustain irreparable damage.

When folding down the pedal, be mindful of a possible crushing risk and do not keep any parts of your body between the contact surface and pedestal.

Deactivating the Pedestal

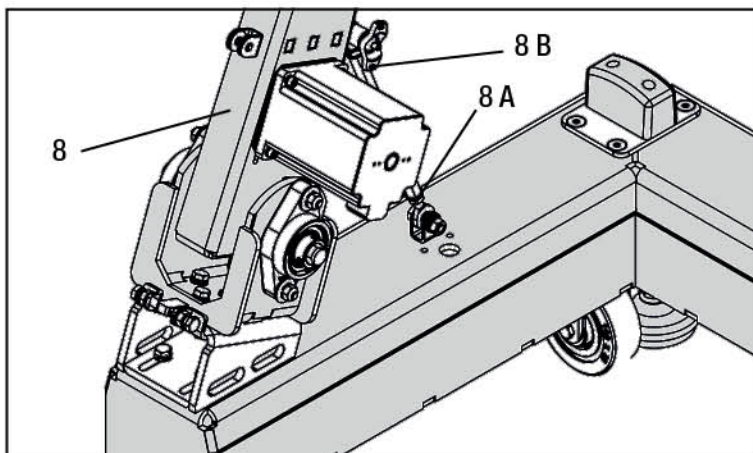

Press the **button for the retaining pin (8 B)**, which holds together the **threaded rod (8 A)** and pedestal, to disengage the lock. Then pull the pin out while firmly holding the pedestal. Carefully lay the pedestal down. Reinsert the retaining pin so as not to lose it. Now switch to the quickarm or sidearm.

To bring the pedestal into the welding position, lift the **pedestal (8)** upward and insert the **retaining pin (8 B)** by pressing the button until it is positioned correctly.

7.10.3 Quickarm

Activating the Quickarm

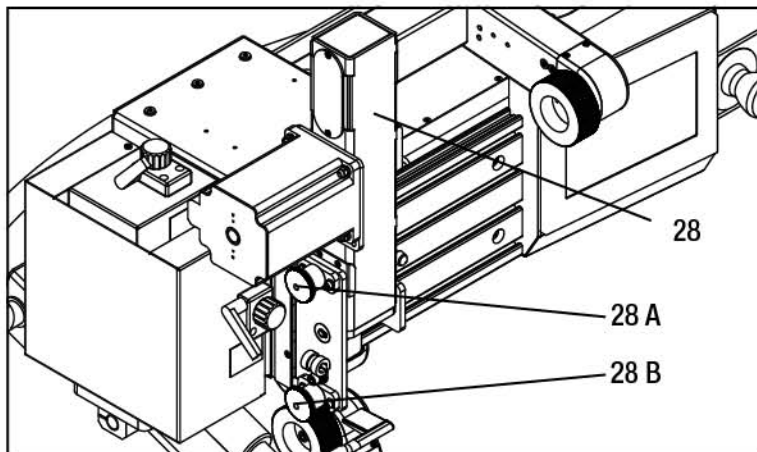

Make sure that the upper transport roller (9) is open.
(See point 7.8.1)

Pull the upper retaining pin (28 A) out, to disengage the locking mechanism for the quickarm (28). Now carefully fold the arm downward and fit the lower retaining pin (28 B) until it fully engages.

Deactivating the Quickarm

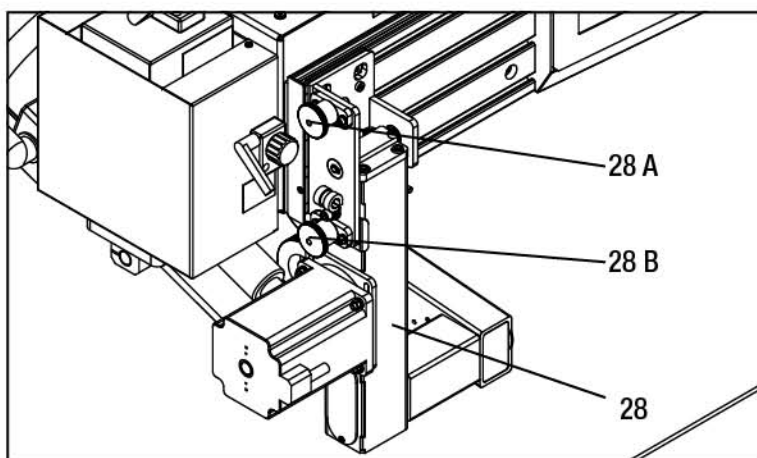

Pull the lower retaining pin (28 B) out, to disengage the locking mechanism of the quickarm (28). Now fold the arm upward into the upper position and insert the upper retaining pin (28 A) until it completely engages.

7.10.4 Sidearm (not available for the SEAMTEK 2000 AT)

Activating the Sidearm

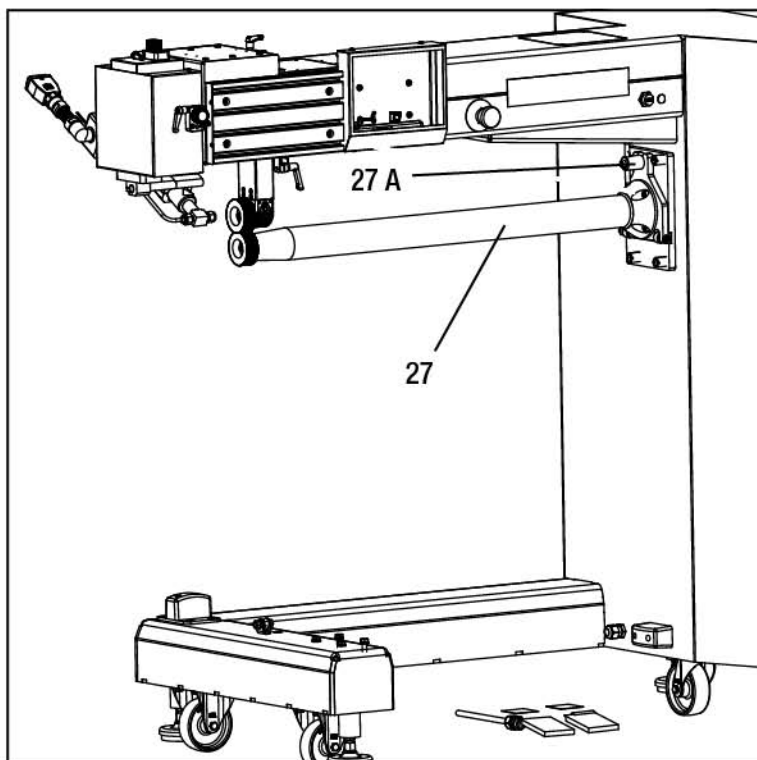

Swivel the sidearm (27) upward and screw the quick release (27 A) in tight.

Deactivating the Sidearm

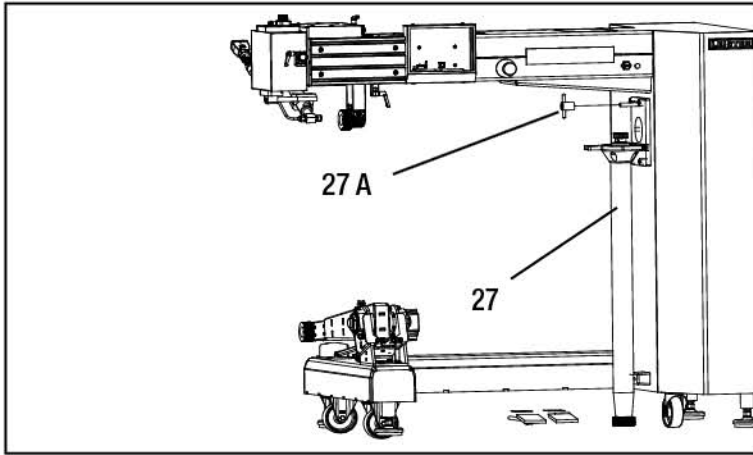

Detach the **quick release (27 A)** and carefully and slowly swivel the **sidearm (27)** downward.

7.11 Transport Rollers

25 mm wide **transport rollers (9)** are mounted as standard.

The powered **transport rollers (9)** clamp and transport the material. The maximum roller speed for original Leister accessory rollers is 30 m/min.

7.11.1 Changing the Transport Rollers



Caution: Fully execute the cool-down mode so that any operating personnel that unintentionally come into contact with hot components when changing the rollers do not suffer burns.

Changing the Pressure Rollers



To change the **transport rollers (9)**, completely cool the machine in advance using the cool-down mode. In the “Periphery” area, set the **NOZZLE**, **CLAMPING PRESSURE**, and **WELD PRESSURE** to “Manual”.

To make the replacement process easier, set the motor to “ON”.

Risk of Crushing



Danger: Do not reach between moving components, e.g., the **transport rollers (9)**. When working on the open system, do not wear articles of clothing such as scarves, shawls, or neckties and tie up long hair or protect it by wearing headgear.

The SEAMTEK AT features two different pressure modes. Using clamp pressure, the material can be positioned prior to the welding process. By default, this pressure is considerably lower than the weld pressure and is intended to protect the operating person from crushing injuries.

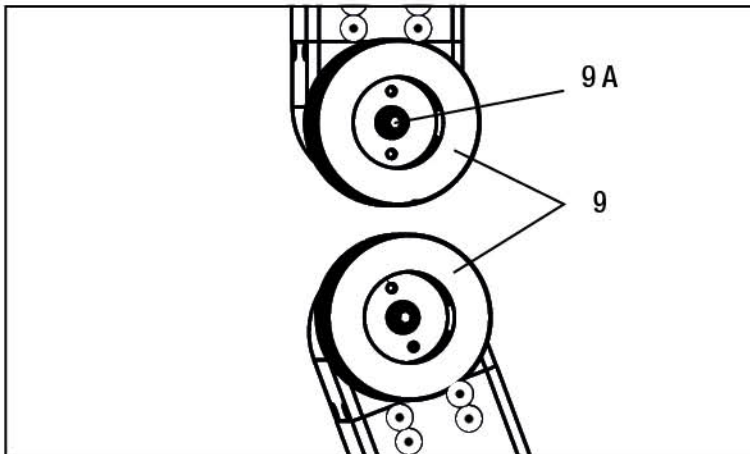

The **transport rollers (9)** are now open and can be changed. Completely detach the **M6 screws (9 A)** and remove these together with the washer. The **transport rollers (9)** can now be easily removed.

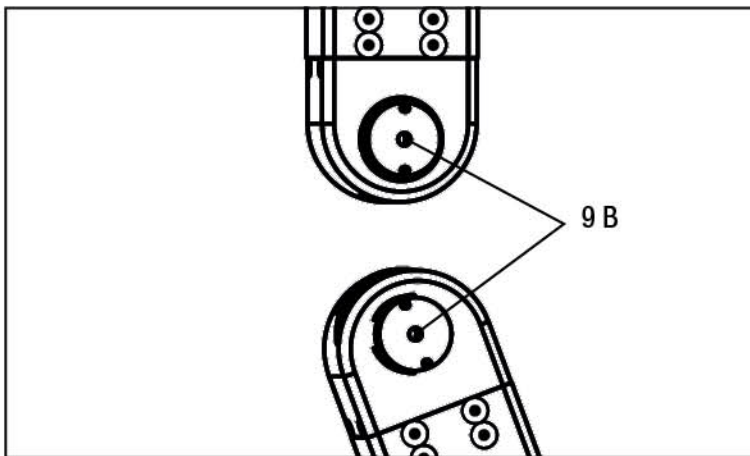

To mount the **transport rollers (9)**, push the **transport roller (9)** onto the **holder (9 B)**. Make sure that the guide pins of the holder match the friction holes of the **transport roller (9)**. Check the seating of the **transport roller (9)**, to ensure that the entire circumference of the roller is fully seated on the holder. Then firmly re-tighten the **M6 screw (9 A)** as well as the washer.

7.12 Guide Holder

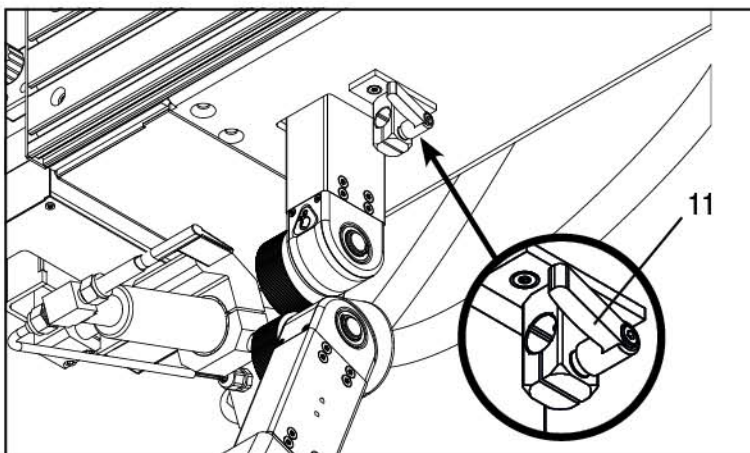

The quick-action coupling for guides enables various accessory guides to be quickly mounted or removed. Turn the clamping lever of the **guide holder (11)** clockwise in order to secure the **guide holder (11)** or anticlockwise in order to detach it.

7.12.1 Mounting and Adjusting the Guide



Caution: First adjust the **welding nozzle (12)** according to Chapter 7.1.1 before the guide is mounted.

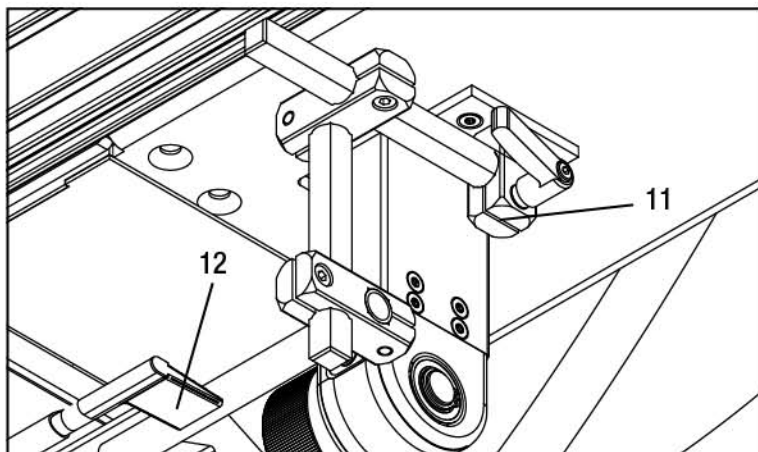

To fasten a guide, check whether the **welding nozzle (12)** has been adjusted. Insert the rod and then clamp the **guide holder (11)** with the clamping lever. The guide can be moved into the desired position on the clamping elements. Once the guide and the **welding nozzle (12)** have been adjusted, check that the **welding nozzle (12)** does not touch anything when swiveling in and out. Different guides are available as accessories. Ask your distribution partner about the various options available.

8. The SEAMTEK AT Control Panel

The **touch panel (2)** consists of a high-quality touchscreen display. Any machine settings can be adjusted on the screen.

8.1 Start screen

After starting up, the start screen is shown on the display together with a number of languages to choose from. Select your language and press the "Start" button.



8.2 Home

The screen changes to the Home view. In this view, all welding parameters can be set and peripheral devices such as the air pump, heating element, and the drive can be switched on.

Tab for changing the view

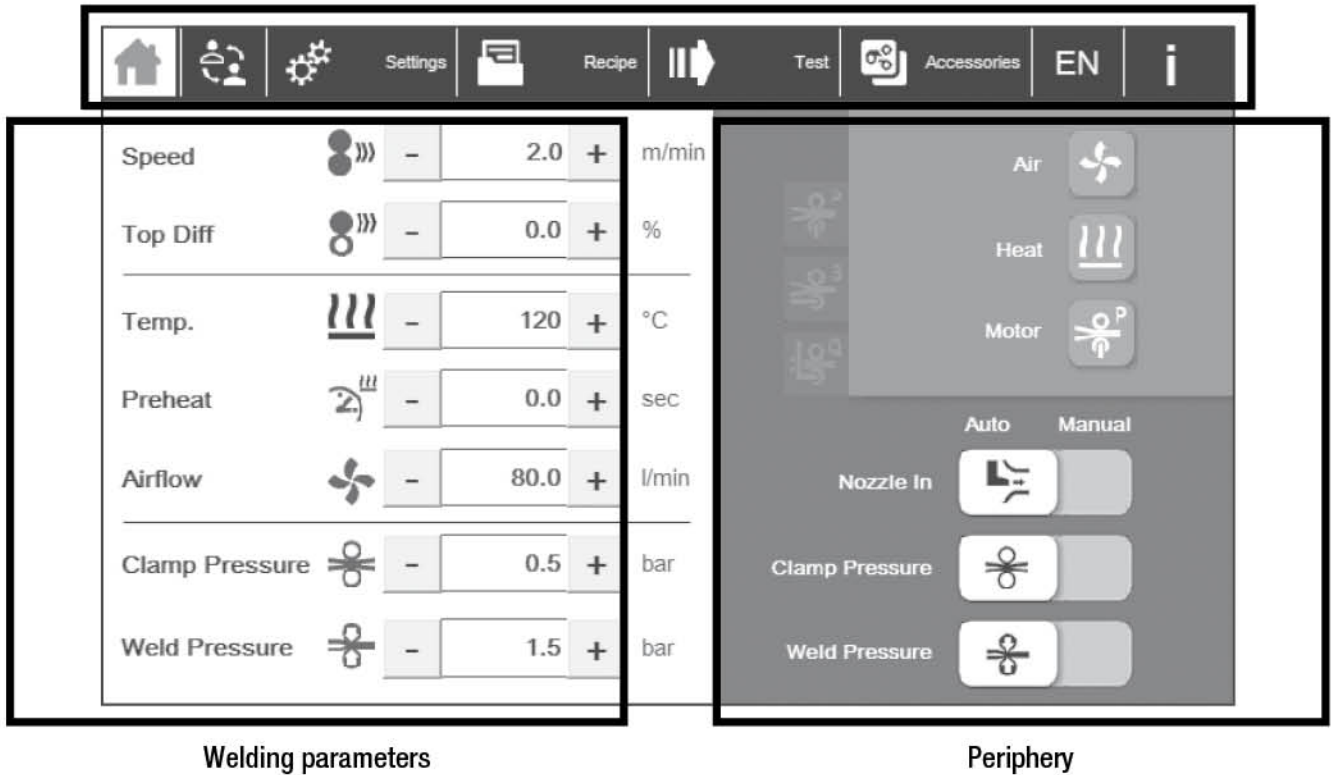









Welding parameters

Periphery







8.3 Tab for Changing Views

At the upper edge of the screen, tabs for individual screen views can be selected. The view you currently see is indicated by the tab selected. The tab for the current view is in white.

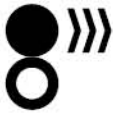



















Symbol	Designation
	Home view
	Select user and change the password
	Adjust machine settings
	Load, save, and delete welding formulas
	Perform test weld to determine parameters
	Select machine accessory
	Choose language
	Information screen (current values, error display and external data storage/load data via USB)



8.4 Welding parameters

The welding parameters are located on the left-hand side of the Home view. Press the respective value to change it. Alternatively, you can increase or decrease the value by selecting **+** or **-**.

Designation	Symbol	
Speed		The roller speed can be set from 0 m/min to 30 m/min.
Upper differential %		The upper roller can be operated with a differential speed to the lower roller. In terms of maximum values, the upper roller can be operated 100% faster (double speed) to 99% slower. If the maximum speed of 30 m/min is exceeded by the differential, the value is automatically adjusted to the "speed". The value of the "upper differential %" is maintained.
Temperature		<p>The temperature has two displays. The value in black indicates the setpoint. In contrast to this, there is a red value that indicates the actual temperature.</p>  <p>If the actual temperature is within +/- 20 °C of the setpoint, only the target temperature (black value) is displayed.</p>
Pre-heating time		The pre-heating time is the time between the last nozzle movement and the start of the transport rollers (9) . By means of the pre-heating time, the transport rollers (9) can be started after a delay in order to heat the material at the start of the weld seam for a longer period of time.
Air volume		<p>The air volume is controlled between the air pump and heating element. Depending on the welding nozzle (12) used, the setpoint must be automatically adjusted by the control unit in the event of a greater deviation between the setpoint and actual value. Any adjustment made to the value is additionally displayed in the reference and error table on the information screen.</p> <p>Note: Adjustments are made to the setpoint if the air pump cannot supply the air volume selected.</p>
Clamping pressure		The clamping pressure is the regulated pneumatic pressure of the clamping cylinder before or after the welding cycle. For safety reasons (risk of entrapment), the clamping pressure has been restricted. This can be set from 0.5 bar to maximum 2 bar.
Welding pressure		The welding pressure is the regulated pneumatic pressure of the clamping cylinder during the welding cycle. The pressure can be set from 0.5 bar to maximum 5 bar.

8.5 Periphery

Air		The air pump is switched off		The air pump is switched on
Heating element		The heating element is switched off		The heating element is switched on
Cool down		<p>When the air pump and heating element are switched on, the cool-down mode can be activated by switching off the air pump. The heating element is switched off and the air pump is run until the heating element has cooled down.</p> <p>Caution–risk of burning: The air nozzle (12), the heating element for the protective pipe (24), or other components may still be hot even after the cool-down process!</p>		
Changing the drive	<p>If you have mounted a “sidearm” or “quickarm” next to the standard welding arm “pedestal”, you can make your selection on the right-hand side of the touch panel (2). The choice of welding arm is represented as an icon on the Home screen. The icons mean the following:</p> <p>Note: To change between the three “pedestal”, “sidearm”, and “quickarm” drives, the motor must be deactivated in advance in each case.</p>			
Pedestal drive		By selecting this tab, the “pedestal” drive can be switched on or off.		
		The “pedestal” drive is switched off.		The “pedestal” drive is switched on.
Sidearm drive		By selecting this tab, the “sidearm” drive can be switched on or off.		
		The “sidearm” drive is switched off.		The “sidearm” drive is switched on.
Quickarm drive		By selecting this tab, the “quickarm” drive can be switched on or off.		
		The “quickarm” drive is switched off.		The “quickarm” drive is switched on.
Welding nozzle (12)		The welding nozzle (12) is in “Automatic” mode and is automatically swiveled in by pressing the “Start/Stop Weld” pedal unit (7) .		
		The welding nozzle (12) is in “Manual” mode and is swiveled out.		The welding nozzle (12) is in “Manual” mode and is swiveled in.
Clamping rollers		The clamping rollers are closed in “Automatic” mode. The clamping pressure selected is applied.		
		The clamping rollers are open in “Manual” mode.		The clamping rollers are closed in “Manual” mode.

Welding rollers		In "Automatic" mode, the welding rollers are closed during the welding process. The welding pressure selected is applied.	
		The welding rollers are in "Manual" mode. The welding pressure is not applied. Welding is not possible.	
Note	To weld material, the welding nozzle (12) and the two transport rollers (9) must be set to "Automatic".		

8.6 User

It is possible to switch between users in this view. The three users have different rights regarding the use and settings of the machine. To change the current user (shaded in gray), select the relevant user – in this case "User" or "Guest" – and enter the password. Log in by pressing the "Log in" button. The following standard passwords are defined as passwords:

Standard passwords:

Admin: 11/User: 22/Guest: 33

You can change these standard passwords. First login in as the user for which you would like to change the password and then select "Change Password".

Now enter the old password. You will then need to enter the new password two times. When entering the password for a second time, make sure that it is identical to the password you entered the first time. Ideally, make a note of the password so that you do not lose it. To reset the password, please contact Leister Technologies AG.

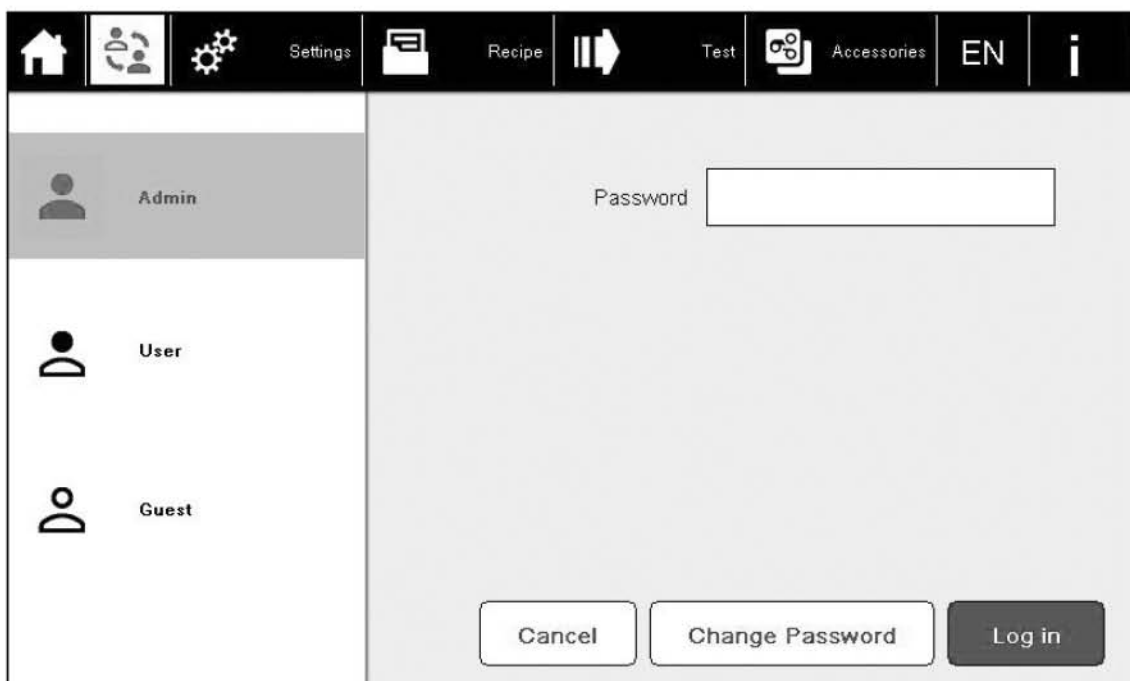

The screenshot shows a user selection interface. At the top, there is a navigation bar with icons for Home, Users, Settings, Recipe, Test, Accessories, EN, and Info. Below the navigation bar, there are three user options: Admin (shaded gray), User, and Guest. To the right of the User option, there is a password input field labeled "Password". At the bottom of the screen, there are three buttons: "Cancel", "Change Password", and "Log in".

Individual users have different authorizations. The table below gives an overview of the authorizations of individual users.

Admin: Full range of functions for commissioning and any repairs to the machine

User: Supervisor, standard functions for machine start

Guest: Shop worker, significantly restricted operation

		User		
Screen	Function	Guest	User	Admin
Home	Tabs can be selected	✓	✓	✓
	Welding parameters (left-hand side)	✗	✓	✓
	Periphery (right-hand side)	✗	✓	✓
User	Tabs can be selected	✓	✓	✓
	Enter password	✓	✓	✓
	Change password	✗	✓	✓
Settings	Tabs can be selected	✗	✓	✓
	Upper wheel diameter	✗	✓	✓
	Lower wheel diameter	✗	✓	✓
	Motor gear teeth	✗	✗	✓
	Driven gear teeth	✗	✗	✓
	Auto reverse distance	✗	✓	✓
	Enable «Pedal Press and Hold»	✗	✗	✓
	Reset button	✗	✓	✓
	Save button	✗	✓	✓
	Touch Calibration	✗	✗	✓
Formula	Tabs can be selected	✗	✓	✓
	Load formula	✗	✓	✓
	Save formula	✗	✓	✓
	Delete formula	✗	✓	✓
Test	Tabs can be selected	✗	✓	✓
Add-ons	Tabs can be selected	✗	✓	✓
	Settings	✗	✓	✓
Language	Tabs can be selected	✗	✓	✓
	Language selection	✗	✓	✓
Info	Tabs can be selected	✓	✓	✓
	Formula backup	✗	✓	✓
	Formula recovery	✗	✓	✓
	Delete alarms	✗	✓	✓
	Setting the date/time	✗	✗	✓

8.7 Machine Settings

In this view, you can change the machine settings. Depending on the user logged in, certain settings are locked or not visible. To display or change all settings, log in as "Admin". (See also the table of authorizations for individual users). The following adjustments can be made:

Setting	Description
Language	In the language selection tab, choose your standard language. Selecting "Save" saves your choice and your language is automatically preselected when the system is re-started. The standard language is English (EN)
Auto reverse distance	Distance that the material is lead back at the end of the weld. With the correct setting, you can achieve a seamless and leak-proof weld seam. As standard, 2 to 3 mm is to be selected.
Upper wheel diameter	Diameter of the upper roller. Standard 63.5 mm
Lower wheel diameter	Diameter of the lower roller. Standard 63.5 mm
Motor gear teeth	Number of gear teeth on the roller shaft. Standard 18
Driven gear teeth	Number of gear teeth on the motor shaft. Standard 26
Enable «Pedal Press and Hold»	As soon as the pedal is no longer being actively actuated, the welding process is interrupted.
Touch Calibration	Recalibrating the touch panel

If you have made a change, you can select the "Save" button to permanently save this adjustment. The next time the system is started up, this new setting will be automatically loaded.

If "Reset" is selected, the standard values described above can be loaded.

The screenshot shows the 'Settings' screen of the machine. The top navigation bar contains icons for Home, User, Settings (active), Recipe, Test, Accessories, Language (EN), and Help (i). The settings are listed as follows:



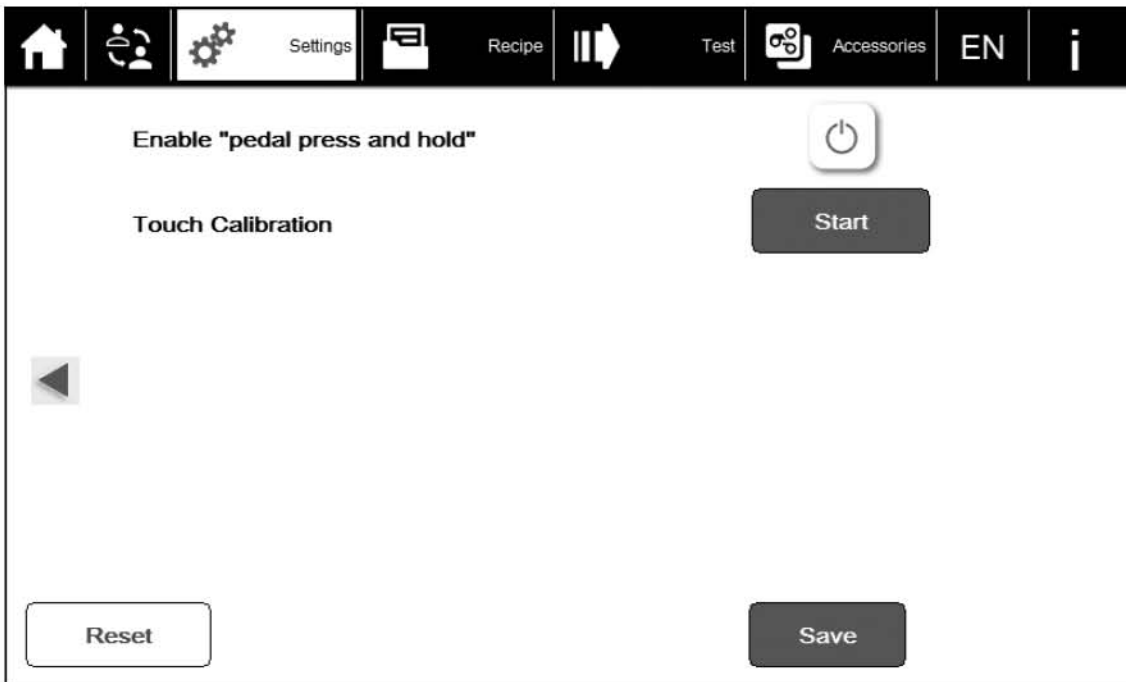

- Language:** EN
- Auto Reverse Distance:** 3.000 mm
- Upper Wheel Diameter:** 63.500 mm
- Lower Wheel Diameter:** 63.500 mm
- Motor Gear Teeth:** 18
- Driven Gear Teeth:** 26

At the bottom of the screen, there are two buttons: 'Reset' on the left and 'Save' on the right.



8.8 Formulas

In this view, you can save your welding parameters as formulas in order to use these again at a later date. You can also save your formulas on an external storage medium for data back-up or load the formulas onto other SEAMTEK AT welding machines. This way you can ensure that all your welding machines work with identical welding parameters. Up to 50 formulas can be saved.

<p>Save formula</p>	<p>Once you have entered your welding parameters in the Home view, select an available formula in order to save your parameters under this formula number. Then select  "Save" and enter a formula name in the window. Press "OK" to confirm and save the formula under the formula number selected.</p>
<p>Delete formula</p>	<p>Select the formula to be deleted and then the button with the wastepaper basket symbol . The formula is deleted without a prompt.</p>
<p>Load formula</p>	<p>To load previously saved formulas, select the respective formula and then press the "Load"  button. You will then be prompted to confirm your selection with "OK". Once the selected formula is loaded, the view switches to the Home view. Pay attention to the formula labels  at the top right when entering the welding parameters. The label contains the formula number selected and is visible until the welding parameters are changed.</p> <p>Note: If, as a result of a very wide welding nozzle (12) and a very high temperature, for example, the selected volumetric flow of the air pump cannot be reached, the volumetric flow automatically decreases. The formula label above is hidden, as the formula parameters no longer match the welding parameters loaded.</p>
<p>Relocate formula</p>	<p>Formulas can be relocated. To do this, select the formula to be relocated and load the formula. Now save the loaded parameters in a new formula location.</p>
<p>Change formula</p>	<p>Load the formula to be changed and edit the formula parameters in the Home view. Delete the previously loaded formula and save your edited welding parameters under the desired formula location.</p>

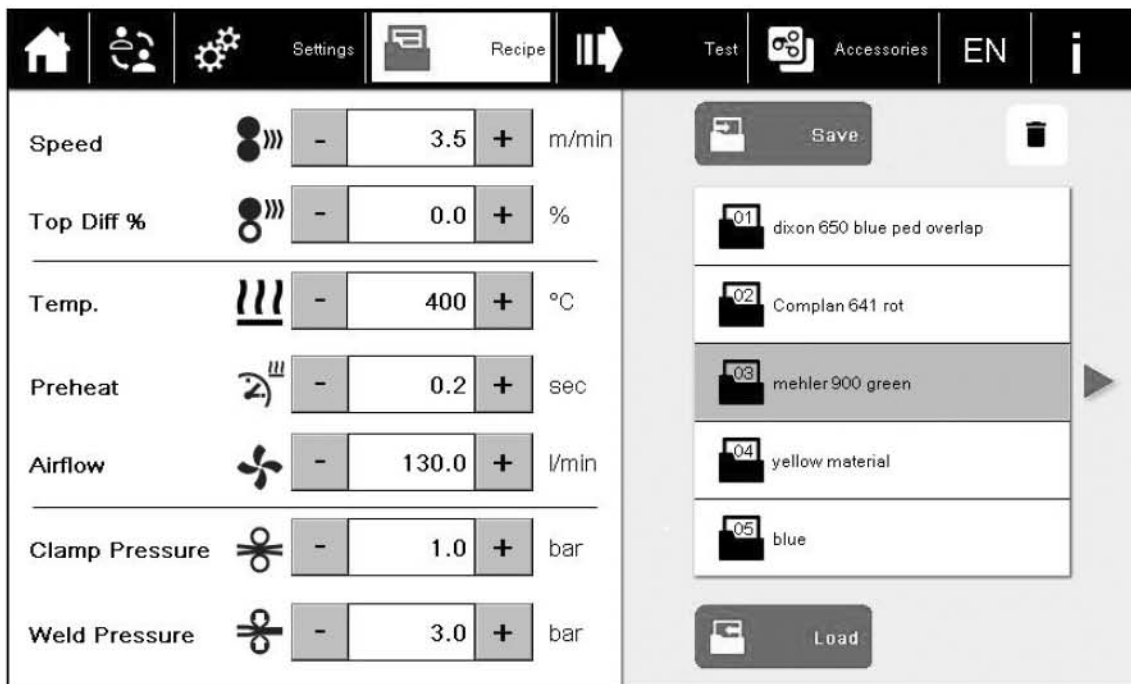

8.9 Test Mode

The test mode enables the optimal welding speed to be determined. To do this, select the "Test" tab in the upper area of the screen. The test mode will guide you through the test step by step.

View 1	<p>For the test, the welding nozzle (12) and transport rollers (9) must be switched to "Auto". To do this, select the following button .</p> <p>Caution: Before doing so, ensure that the nozzle is adjusted in accordance with point 7.1.1. When the button is pressed, open transport rollers (9) can close and the welding nozzle (12) can switch to the run-in position.</p>
View 2	Switch on the air pump, heater, and drive.
View 3	<p>Prepare a test strip of slightly more than 550 mm/21.7 inches and position the material between the clamps.</p> <p>Enter the approximate welding speed in the left-hand window area. The welding process for the test strip begins with +50% of this approximate welding speed and is linearly reduced to -50%. Start the test weld using the foot pedal of the "Start Weld" pedal unit (7).</p>

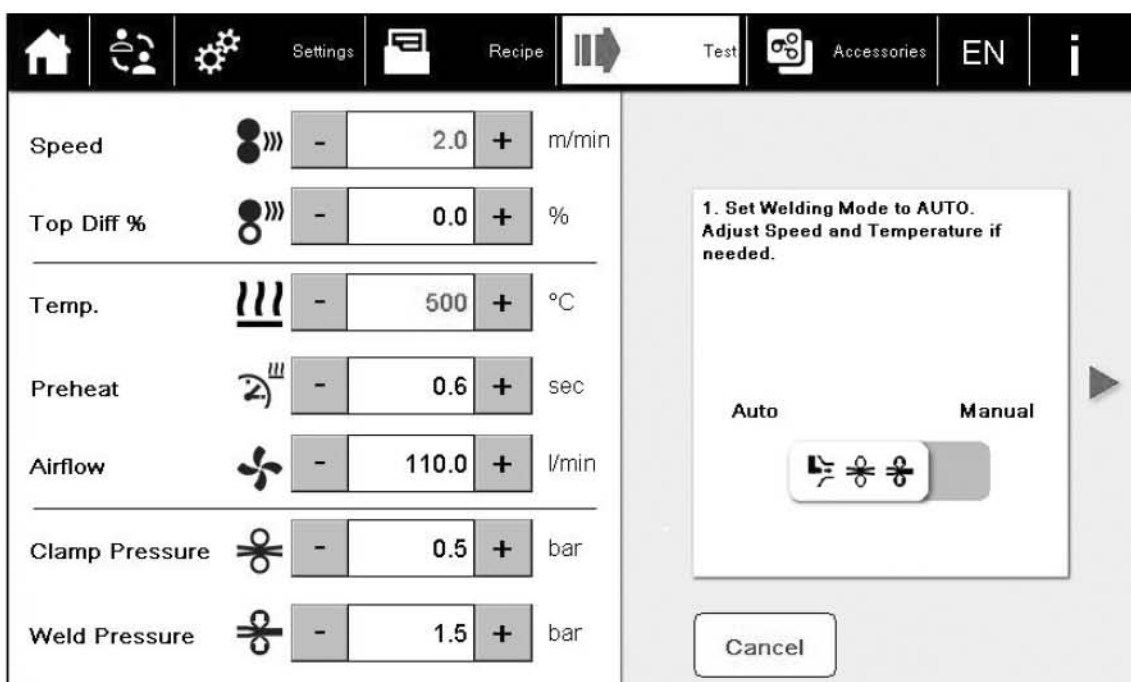

View 4	<p>Carefully tear the test strip starting from the beginning of the weld and measure the distance from the start of the test strip to the point where there is a good weld seam. Enter this value in millimeters or inches in the input window displayed.</p> <p>Note: If the strip was welded well right at the start of the seam, then carry out the test mode again with a higher approximate speed. If the seam is insufficiently joined, perform the test mode again with a lower approximate speed.</p>
View 5	<p>The optimal welding speed is calculated on the basis of the approximate welding speed and the distance measured. Confirm with "OK" to adopt the value and switch to the Home view.</p>

8.10 Add-Ons Screen

In the Add-ons view, additional devices, such as a puller or tape cutting unit, can be switched on or off and parameterized. To operate these devices, please observe the operating instructions separately enclosed with the product.

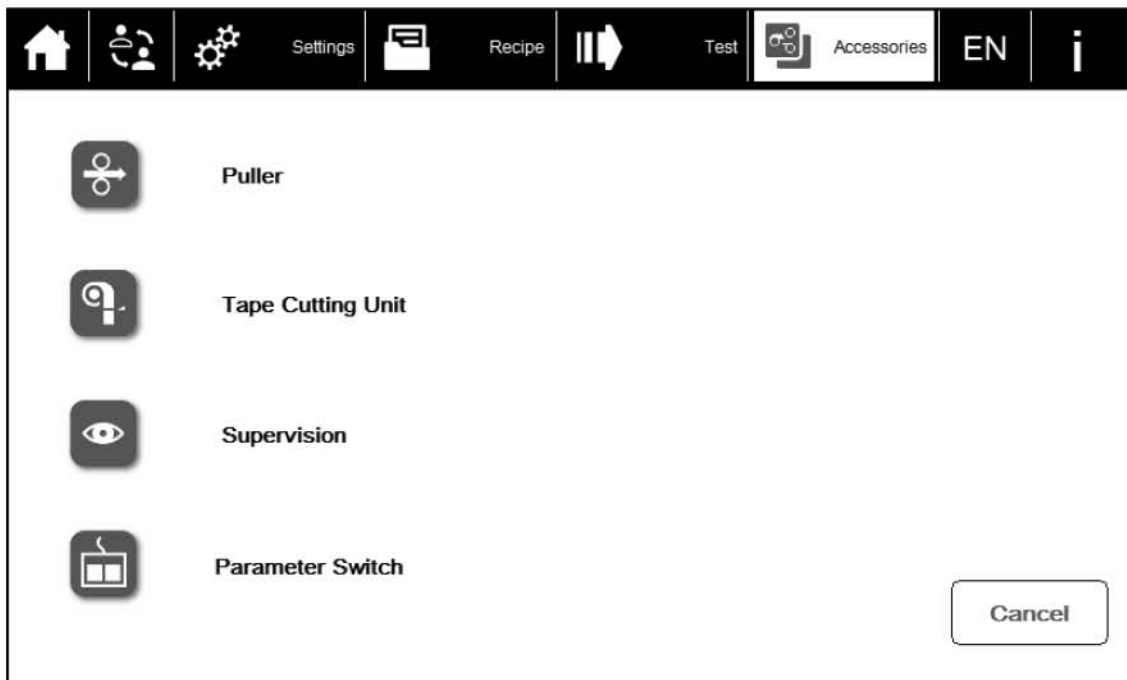

8.11 Information

The Information view enables users to see the process data for simplified troubleshooting or fault localization. In addition, in the event of an error, errors are displayed in the alarm list with the date/time of the first occurrence, error number, and a brief error description. If an error occurs, please refer to Chapter 10 Warning and Error Messages (Troubleshooting/Q&A).

The screenshot displays the Information view interface. At the top, there is a navigation bar with icons for Home, User, Settings, Recipe, Test, Accessories, and Language (EN). Below the navigation bar, there are several settings sections:

- Temp.: 500 °C
- Clamp/Weld Press.: 1.50 bar
- Inlet Air Flow: 110 l/min
- Selected Arm: PEDESTAL
- PWM: 0 %
- Weld Pedal: FALSE
- Raise Pedal: FALSE
- Wedge: FALSE
- Machine Settings: Backup Recovery
- Recipes: Backup Recovery

Below the settings is a table of alarms:

	Date/Time (CEST/CET)	Nr.	Alarm-Description
0	-	0	-
1	-	0	-
2	-	0	-
3	-	0	-
4	-	0	-
5	-	0	-

At the bottom of the interface, there is a status bar with the following information:

- Delete Alarms button
- State: SBY
- Software Version: V160512
- Time: 10:58:18

Date/time

8.12 Setting the date/time

To change the date and time, the user must be logged in as an administrator (chapter 8.6). Then click on the Time field and make your adjustments.

9. Welding Sequence and Tips

9.1 Welding Sequence

Preparing a Weld/Test Mode

To prepare a weld, the welding parameters must be defined. It is advisable to gradually adjust the parameters while using small test strips and the same material pairing until a good weld seam can be achieved. Alternatively, the test mode can be used (see Chapter XY).

Performing a Weld

Press the left pedal (Raise Wheel) of the **pedal unit (7)**, to raise the upper rollers. Now place the material as required and release the pedal. The material is now compressed with the defined clamping pressure. Ensure that there is a sufficiently large gap in front of the **transport rollers (9)**, so that the **welding nozzle (12)** has enough space between the materials. Start the welding process with the right pedal of the **pedal unit (7)** (Start weld). The **welding nozzle (12)** now moves into the welding position. Depending on the pre-heating time set, the **transport rollers (9)** begin to turn after a delay and transport the material. Guide the material freely or using the optional guides. In the meantime, you can interrupt the welding process with the same pedal. Continue the welding process until the end. As soon as the welding process has stopped, you can completely end it using the (Raise Wheel) pedal and remove the material.

Switching Off the Machine

Switch off the air supply via the tab. The machine now automatically goes into cool-down mode. Allow the machine to completely cool down until the pump switches off. You can then operate the **main switch (5)** and switch off the machine.

9.2 Tips for a Better Weld Result

Material Tension

Try to feed the material into the welding zone with as little tension in the material as possible. In practice, tension is inevitable but can be significantly reduced by feeding in the material correctly.

Pay attention to how the material leaves the welding zone too. The still warm weld seam should not immediately fall downward upon leaving the welding zone. The cooling phase should also be as tension-free as possible. It is advisable to use a table or other similar object on which the material can rest after it leaves the welding zone.

Speed

Feeding in material requires experience. Personnel new to the process should start with a lower welding speed (and an accordingly lower welding temperature) to get a feel for feeding in the material. The speed can then be increased in increments.

Cold Run-Through

To begin with, practice the welding sequence with a complex shape without swiveling in the **welding nozzle (12)**. Set the tab for the **welding nozzle (12)** to "Manual". By doing this, you can get a feel for the weld shape without damaging the material to be processed.

Be Ready to Stop the Welding Process

Be mindful of the fact that you can stop the welding process at any time with the right pedal of the **pedal unit (7)**. In the event of a material feed error, this enables you to stop the welding process and realign the material. With the adjustable pre-heating time, you can then completely seal the seam.

Save Formulas

Save formulas in a logical place for repeat orders. This makes it considerably easier to determine parameters when welding the same material again.

Guides

Use the guides that are available as accessories. Correctly adjusted guides guide the material and enable a consistent weld seam. Ask your distributor for information on the various guides available.

Regular Breaks

Working on the SEAMTEK AT requires a level of concentration – if you feel stressed, take a break.

10. SEAMTEK AT Warning and Error Messages

10.1 Error Levels

Any errors that occur are separated into two levels by the machine control unit. The errors are differentiated on the basis of their impact on the process, machine, and persons.

Table 1: error differentiation

Error Level	Designation	Impact	Action
1 or 1xx	Technical warning	No or minor impact on the process	Note display in error list. Tab for the information screen not displayed in red.
2 or 2xx	Process error	Significant impact on the ongoing process.	Display in error list and tab for the information screen is displayed in red. (E.g., temperature below normal value)

10.2 Error List

The error number is shown for the Leister Support team in the information text. Error numbers using a basis of 100 indicate the error level, e.g., 201 is a level 2 error. Error 01 is a level 1 error.

All errors that are trapped and/or signaled by the control unit are then listed.

Table 2: list of all errors



Error No.	Level	Info Text	Description
100	1	Warning 100: Air Flow lowered. Check Value.	Air Flow Set point adjusted (lowered). Check and correct if necessary. Max. pump power limit reached.
101	1	Warning 101: Air Flow increased. Check Value.	Air Flow Set point adjusted (increased). Check and correct if necessary. Max. pump power limit reached.
102	1	Warning 102: Reset of Air Volume Controller. Too high Setpoint.	Air Volume can not be reached. Setpoint is too high.
103	1	Warning 103: Reset of Air Volume Controller. Too low Setpoint.	Air Volume can not be reached. Setpoint is too low.
200	2	Error 200: P-Puller Motor Driver Error	Beckhoff driver error (Puller). Check for Overload.
201	2	Error 201: Upper Motor Driver Error (Quickarm or Upper Wheel Module).	Beckhoff driver error (Upper Wheel Module). Check for Overload. Press button "Delete Alarms"
202	2	Error 202: Lower Motor Driver Error (Pedestal or Sidearm).	Beckhoff Treiber Error (Pedestal, Sidearm or Upper Wheel Module). Check for Overload. Press button "Delete Alarms"
203	2	Error 203: No Temperature Sensor/ Heater connected	No Thermocouple connected for longer than 2 min. Display 1372 °C / 2412 °F = no Thermocouple connected
204	2	Error 204: Reading Machine Settings File. Check Machine Settings	In StateMachine() Machine Settings File can not be read. Standard Values applied. All Passwords set to 1234

208	2	Error 208: Cannot open Backup Source File.	Recipe File on PLC corrupted. Do recover your Data from your Memory Stick.
209	2	Error 209: Can not open Backup Destination File.	Missing Memory Stick.
210	2	Error 210: Can not read Backup Source File.	Recipe File on PLC corrupted. Do recover your Data from your Memory.
211	2	Error 211: Can not write Backup Destination File.	Missing Memory Stick.
212	2	Error 212: Can not close Backup Destination File.	Missing Memory Stick.
213	2	Error 213: Can not close Backup Source File.	Recipe File on PLC corrupted. Do recover your Data from your Memory.
214	2	Error 214: Can not open Recovery Source File.	Recipe File on Memory Stick corrupted. Do backup your Data from PLC to Memory Stick.
215	2	Error 215: Can not open Recovery Destination File.	Recipe File on PLC corrupted.
216	2	Error 216: Can not read Recovery Source File.	Recipe File on Memory Stick corrupted. Do backup your Data from PLC to Memory Stick.
217	2	Error 217: Can not write Recovery Destination File.	Recipe File on PLC corrupted.
218	2	Error 218: Can not close Recovery Destination File.	Recipe File on PLC corrupted.
219	2	Error 219: Can not close Recovery Source File.	Recipe File on Memory Stick corrupted. Do backup your Data from PLC to Memory Stick.
220	2	Error 220: Open File in Read Machine Settings	In SettingsRead() Error Machine Settings Open File. All Passwords set to 1234
221	2	Error 221: Read CSV Line in Read Machine Settings	In SettingsRead() Error Read CSV Line Machine Settings
222	2	Error 222: Close File in Read Machine Settings	In SettingsRead(), Error Closing File
230	2	Error 230: Open File in Write Machine Settings	In SettingsWrite() Error Machine Settings Open File
231	2	Error 231: Write CSV Line in Write Machine Settings	In SettingsWrite() Error Write CSV Line Machine Settings

Error No.	Level	Info text	Description
232	2	Error 232: Close File in Write Machine Settings	In SettingsWrite(), Error Closing File
240	2	Error 240: Open File in Read Recipes	In RecipesRead(), Error Recipes Open File
241	2	Error 241: Read CSV Line in Read Recipes	In RecipesRead (), Error Read CSV Line Recipes
242	2	Error 242: Close File in Read Recipes	In RecipesRead (), Error Closing File
250	2	Error 250: Open File in Write Recipes	In RecipesWrite() Error Machine Settings Open File
251	2	Error 251: Write CSV Line in Write Recipes	In RecipesWrite (), Error Write CSV Line Machine Settings
252	2	Error 252: Close File in Write Recipes	In RecipesWrite (), Error Closing File
258	2	Error 258: Can not open Backup Source File.	Machine Settings File on PLC corrupted. Do recover your Data from your Memory Stick.
259	2	Error 259: Can not open Backup Destination File.	Missing Memory Stick.
260	2	Error 260: Can not read Backup Source File.	Machine Settings File on PLC corrupted. Do recover your Data from your Memory.
261	2	Error 261: Can not write Backup Destination File.	Missing Memory Stick.
262	2	Error 262: Can not close Backup Destination File.	Missing Memory Stick.
263	2	Error 263: Can not close Backup Source File.	Machine Settings File on PLC corrupted. Do recover your Data from your Memory.
264	2	Error 264: Can not open Recovery Source File.	Machine Settings File on Memory Stick corrupted. Do backup your Data from PLC to Memory Stick.
265	2	Error 265: Can not open Recovery Destination File.	Machine Settings File on PLC corrupted.
266	2	Error 266: Can not read Recovery Source File.	Machine Settings File on Memory Stick corrupted. Do backup your Data from PLC to Memory Stick.
267	2	Error 267: Can not write Recovery Destination File.	Machine Settings File on PLC corrupted.
268	2	Error 268: Can not close Recovery Destination File.	Machine Settings File on PLC corrupted.
269	2	Error 269: Can not close Recovery Source File.	Machine Settings File on Memory Stick corrupted. Do backup your Data from PLC to Memory Stick.
270	2	Error 270: Air Temperature Setpoint not reached. Lower Airvolume or Temperature Setpoint, restart Heater	Air Temperature during Heat-Up (slow Controller) can not be reached. Setpoint is too high, Air Volume is too high. Ambient Temperature or Inlet Air Temperatur of SEAMTEK AT is too low.

271	2	Error 271: Air Temperature Setpoint too high. Heat Controller Restart initiated	Air Temperature during Heat-Up (slow Controller) can not be reached for long Time. Air Temp. Controller has been reset. Stop and restart Heating.
272	2	Error 272: Wedge Temperature Setpoint not reached. Lower Airvolume or Temperature Setpoint, restart Heater	Wedge Temperature can not be reached. Setpoint is too high or Ambient Temperature of SEAMTEK AT is too low.
273	2	Error 273: Wedge Temperature Setpoint too high. Heat Controller Restart initiated	Wedge Temperature can not be reached for long Time. Wedge Temp. Controller has been reset. Stop and restart Heating.
274	2	Error 274: Air Temperature Setpoint not reached. Lower Airvolume or Temperature Setpoint, restart Heater	Air Temperature of fast Controller can not be reached. Setpoint is too high, Air Volume is too high. Ambient Temperature or Inlet Air Temperatur of SEAMTEK AT is too low.
275	2	Error 275: Air Temperature Setpoint too high. Heat Controller Restart initiated	Air Temperature of fast Controller can not be reached for long Time. Air Temp. Controller has been reset. Stop and restart Heating.
276	2	Error 276: PWM for slow Hot Air Controller too low. Check Thermocouple.	PWM < 50. Thermocouple not connected or broken.
277	2	Error 277: PWM for fast Hot Air Controller too low. Check Thermocouple.	PWM < 50. Thermocouple not connected or broken.
280	2	Error 280: Shop Air Pressure too low. Clamp Pressure Setting lowered.	Shop Air Pressure too low. Check and increase Pressure to min 6 bar. Clamp Pressure Set point adjusted (lowered). Check and correct if necessary.
281	2	Error 281: Shop Air Pressure too low. Weld Pressure Setting lowered.	Shop Air Pressure too low. Check and increase Pressure to min 6 bar. Weld Pressure Set point adjusted (lowered). Check and correct if necessary.

11. Frequently Asked Questions

	Problem	Solution
1	Changing rollers: The welding rollers can only be detached with difficulty.	<p>To change the rollers, swivel out the nozzle</p>  <p>and switch on the motor for the welding arm used.</p>  <p>Press the "Raise Wheel" pedal.</p>  <p>The rollers are now blocked for five minutes and can be changed without any problems.</p>
2	Display of negative temperature values . Rapid and repeating heating-up phases.	The thermocouple has not been connected properly. Observe the polarity of the connecting wires. Please refer to the wiring diagram for the polarities and wire colors for the correct connection.

3	Display of temperature values remains unchanged (usually around 40 – 65 °C). Rapid and repeating heating-up phases.	When connecting the thermocouple, the connecting wires are short-circuited . Check the connection. At the point of measurement, the thermocouple short circuits . Replace the thermocouple.
4	After replacing the thermocouple, the temperature display is faulty: The screen displays 1372 °C, respectively 2412 °F . Error 203 occurs.	The thermocouple was not connected or is interrupted .
5	Automatic reduction of air volume: In the case of very wide nozzles and high welding temperatures, the desired volumetric flow is sometimes not achieved. The air volume set automatically decreases by 10 l/min.	The performance of the air pump is limited. To achieve consistent welding results, the volumetric flow is reduced to a controllable value. At the start of the weld, choose a lower volumetric flow .
6	No temperature increase at the welding nozzle	<p>Ensure that the heater is switched on. </p> <p>If the heater is active, the display value "PWM" is displayed in green on the information screen.</p> <div data-bbox="687 819 1043 880" style="border: 1px solid black; padding: 2px; margin-bottom: 5px;"> PWM 0 % </div> <p>If the heater is switched off, the display is shown in red.</p> <div data-bbox="687 943 1043 1003" style="border: 1px solid black; padding: 2px; margin-bottom: 5px;"> PWM 0 % </div> <p>If this value is greater than 20% and no temperature increase can be determined at the welding nozzle, replace the heating element.</p>
7	Significant wave formation at the weld seam	<p>Make sure that the correct arm (pedestal, quickarm or sidearm) has been selected in the Home view.</p> <p>The wave formation can be reduced or prevented by inputting the upper differential (the upper roller can be operated with a differential speed to the lower roller).</p> <p>Make sure that the information input in the "Settings" tab under upper roller Ø and lower roller Ø is correct.</p> <p>By default, these two values are 63.5 mm.</p>

12. Maintenance





Danger to life, high voltage! Before opening the switch cabinet, the device must be disconnected from the power supply at all poles (disconnect the power plug.) Live components and connections may be exposed in the process.



Device may be operated only by **trained specialists** or under their supervision.

Time period	Monitoring and maintenance work	Spare parts	Tools
As Necessary	<ul style="list-style-type: none"> • Clean the welding nozzle (12) with a brass brush designed for this purpose • Clean or replace the air filter 	Air filter	Brass brush
Daily before Start-Up	<ul style="list-style-type: none"> • Check the stability of the machine • Check the machine and power cable for damage • Check the control pressure of the maintenance unit (max. 10 bar/ min. 6.5 bar.) 	–	–
Weekly	Clean the entire machine	–	wet towel
Monthly	Clean the compressed air filter of the rotary vane pump.	Filter set (156.777)	Isopropyl alcohol Compressed air
Monthly	Clean the maintenance unit filter.	Filter set (156.777)	Isopropyl alcohol Compressed air
6 months	Clean or replace the filter for the switch cabinet. Depending on the ambient conditions.	Filter set (156.777)	Isopropyl alcohol Compressed air
2 years	Replace the compressed air filter of the rotary vane pump.	Filter set (156.777)	
2 years	Replace the maintenance unit filter.	Filter set (156.777)	

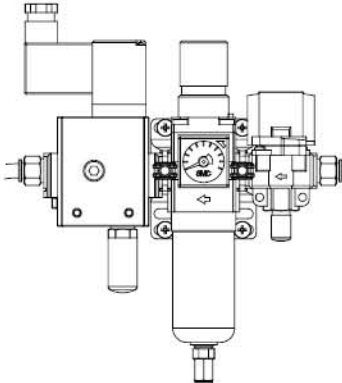
No.	Designation	Text	Figure
1	Filter in switch cabinet	<p>The air filter must be cleaned every six months.</p> <ul style="list-style-type: none"> • Detach the countersunk screw (26, A). • Remove the chromium steel cover (26, B). • Remove the filter mat (26, C) and rinse the mat under cold water. • Blow down and dry the filter mat with compressed air. • Re-fit the filter (70), cover (60), and screws (100). <p>The filter must be replaced every two years. The filter is included in the filter set (156.777).</p>	
2	Compressed air filter for rotary vane pump	<p>Before using the machine, always clean the filter element (156.778) with isopropanol to prevent damage. The filter must be replaced every two years. The filter is included in the filter set (156.777).</p> <ul style="list-style-type: none"> • When installing the reservoir on the filter, ensure that the locking knob is aligned with the nut on the front (or rear) of the housing in order to prevent the reservoir from falling off or becoming damaged. • Before removing the filter reservoir, the pressure must be removed from the system. • For detailed information on disassembling and assembling the filter, see reference document in annex 	

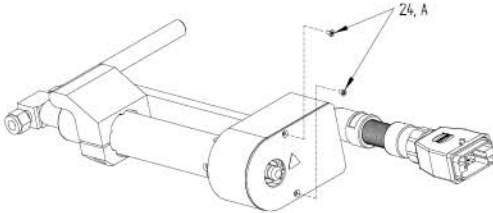
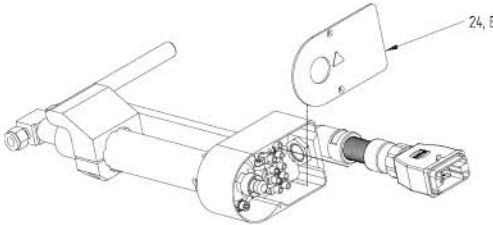
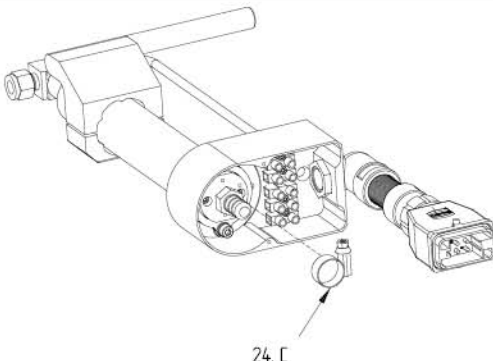
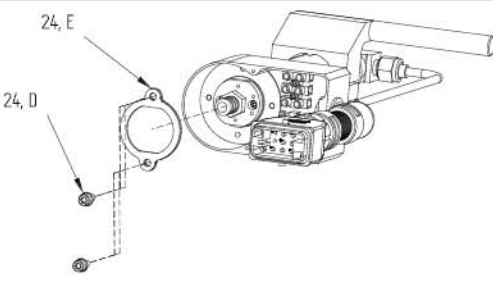
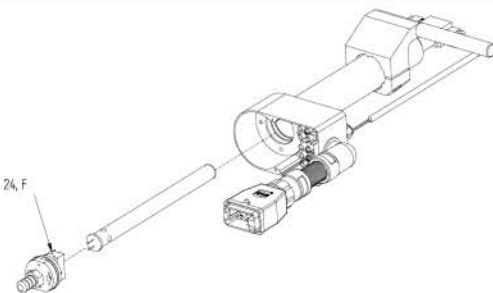
No.	Designation	Text	Figure
3	Filter maintenance unit	<p>Before using the machine, always clean the filter element with isopropanol to prevent damage. The filter must be replaced every two years. The filter is included in the filter set (156.777).</p> <ul style="list-style-type: none"> • Before removing the filter reservoir, the pressure must be removed from the system. • For detailed information on disassembling and assembling the filter, see reference document in annex 	
4	Change heating element	<p>1. Remove the screws (24, A)</p> <div style="display: flex; align-items: center;">  <p>Danger to life, because of voltage-bearing component. Before opening the switch cabinet, the device must be disconnected from the power supply at all poles. (Disconnect the power plug.)</p> </div>	
		2. Remove the cover (24, B)	
		3. Detach the hose clip (24, C) and pull the hose from the connector.	
		4. Detach the screws (24, D) and remove the fixture (24, E)	
		5. Pull at the holder for the heating element (24, F) and pull the element out of the housing.	

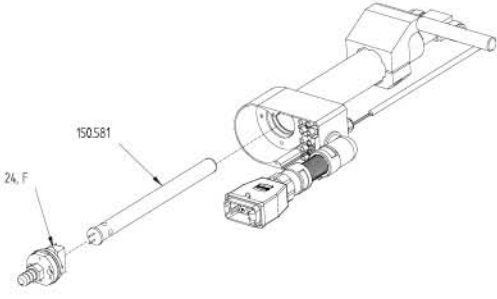
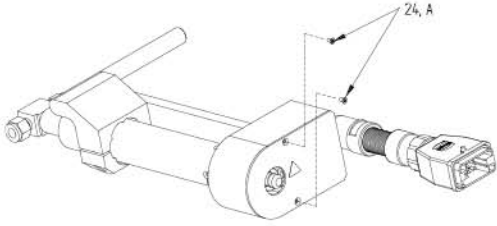
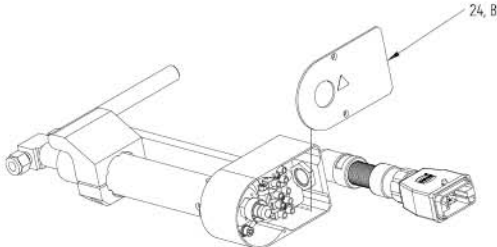
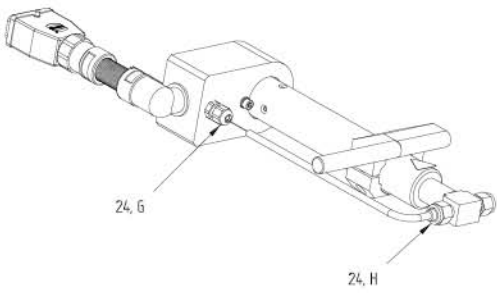
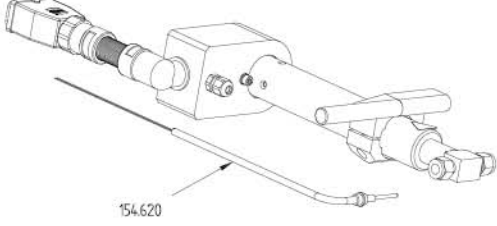
		<p>6. Separate the heating element (150.581) from the holder (24, F) and insert the new heating element.</p>	
		<p>7. Re-assemble the elements following the disassembly steps in reverse.</p> <p>CAUTION: There is a risk of burning when changing the heating element. This process must only be performed after the cool-down mode.</p>	
5	Change the thermocouple	<p>1. Remove the screws (24, A)</p>	
		<p>2. Remove the cover (24, B). Detach the white and green cable on the side of the thermocouple.</p>	
		<p>3. Loosen the nut of the lead-through (24, G) and the nut on the T-piece (24, H)</p>	
		<p>4. Remove the thermocouple (154.620) and replace it with a new one.</p>	
		<p>5. Re-assemble the elements following the disassembly steps in reverse.</p>	
		<p>CAUTION: There is a risk of burning when changing the heating element. This process must only be performed after the cool-down mode.</p> <p>CAUTION: The thermocouple may be stuck as a result of the significant temperature difference. Do not apply any force. Try to detach the element by gently knocking it.</p>	

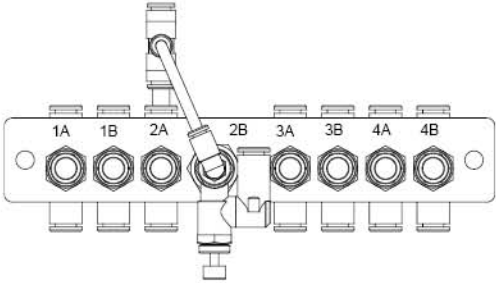
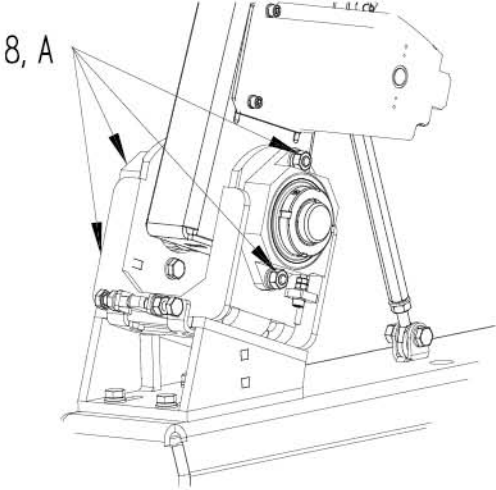
6	Inductor unit	<p>In the case of significant differences in temperature or extended periods of use, the axis movement of the welding nozzle and pressure roller can shift.</p> <p>To compensate for these changes, fine adjustments can be made using the inductor unit.</p> <p>Axis control: 1A, 1B Z-axis of roller 2A, 2B Z-axis of nozzle 3A, 3B X-axis of nozzle 4A, 4B Y-axis of nozzle</p> <p>1A Control the clamping movement of the roller 1B Control the opening movement of the roller</p> <p>2A Nozzle Z-axis Control upward movement 2B Nozzle Z-axis Control downward movement</p> <p>3A Nozzle X-axis Control extension movement 3B Nozzle X-axis Control retraction movement</p> <p>4A Nozzle Y-axis Control extension movement 4B Nozzle Y-axis Control retraction movement</p>	
7	Displacement of the welding arm (pedestal)	<ol style="list-style-type: none"> 1. Swiveling of the welding arm (pedestal) 2. Skew 3. Height 4. Length 5. Width <p>1.1 Detach the nuts (8, A) on both sides.</p>	

1.2 Use the screws (8, B) to adjust the angle of the welding arm.

Caution:
Following the adjustment process, tighten the nuts.

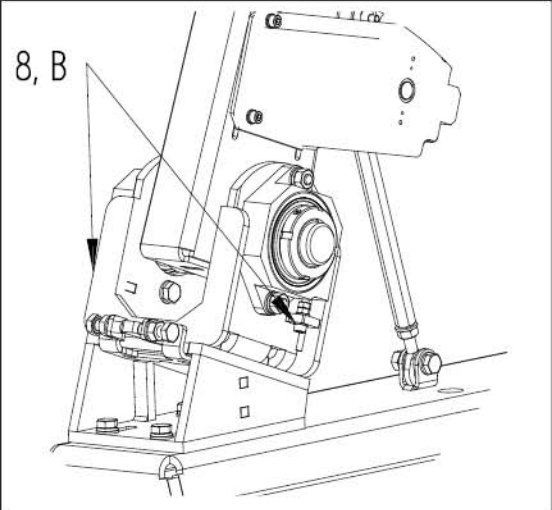

2.1 Detach the screws (8, C)

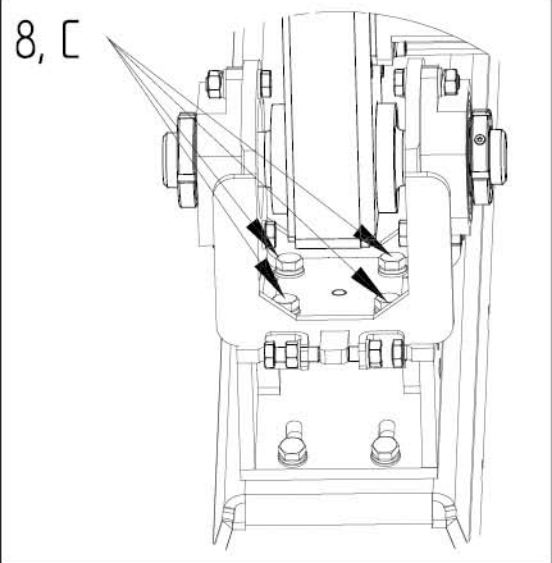

2.2 Adjust the welding arm using the screws (8, D)

Caution:
Following the adjustment process, tighten the screws.

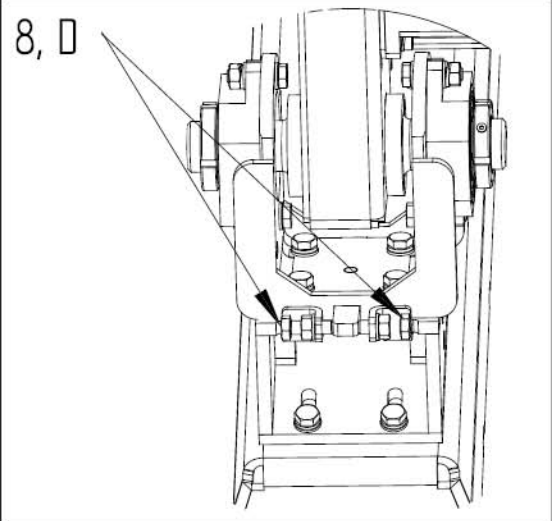

3.1 Detach the nuts (8, E)

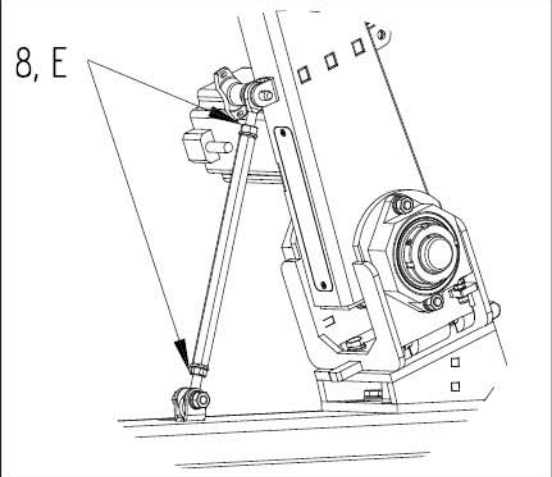

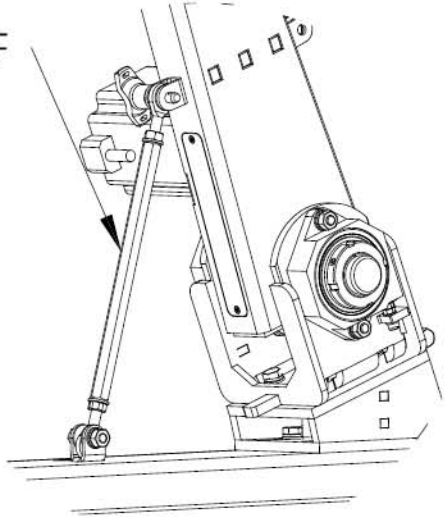
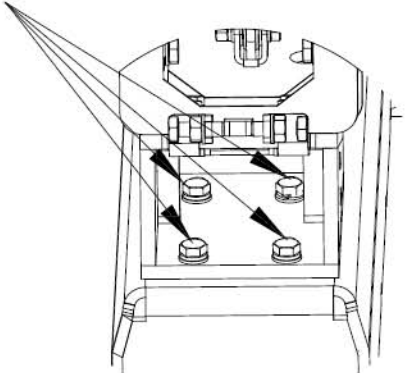
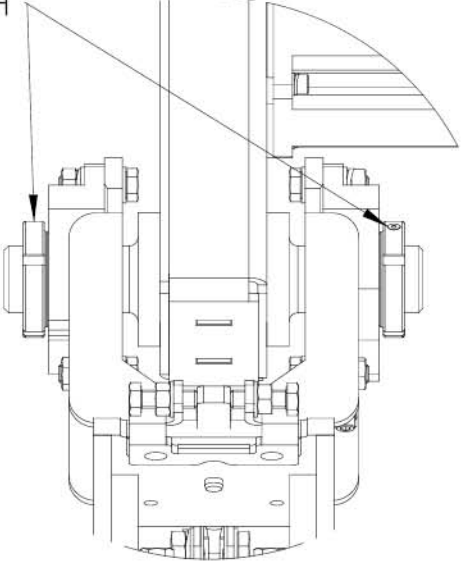
		<p>3.2 Now use the rod to adjust the height of the welding roller.</p> <p>Caution: Following the adjustment process, tighten the nuts.</p>	<p>8, F</p> 
		<p>4.1 Detach the screws (8, G) on both sides.</p>	<p>8, G</p> 
		<p>4.2 Manually move the welding arm backward or forward.</p> <p>Caution: Following the adjustment process, tighten the screws.</p>	
		<p>5.1 Detach the safety screw on both sides (8, H)</p>	<p>8, H</p> 

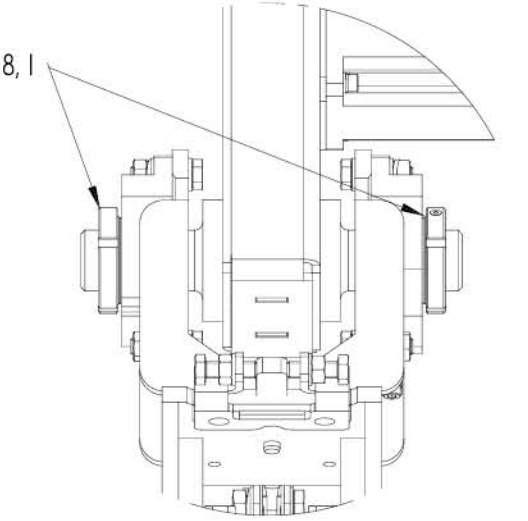
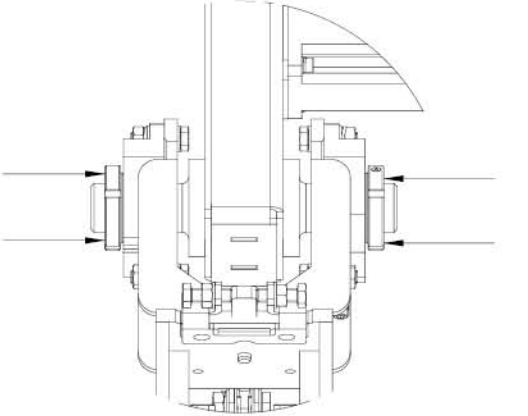
		<p>5.2 Detach the nuts (8, l) on both sides.</p>	
		<p>The chuck cone of the clamping unit is seized. Move the nuts axially using a plastic hammer until the clamping sleeve is loose. Manually move the welding arm to the left or right.</p> <p>Caution: Following the adjustment process, tighten the nuts and screws.</p>	

12.1 Machine Fault

Machine blockages can occur if the weld material is not lead downstream of the welding zone unimpeded. If a machine fault/ blockage occurs during the welding process, end the weld immediately with the right pedal of the **pedal unit (7)**. In the event of this, set NOZZLE IN, CLAMP PRESSURE, and, WELD PRESSURE to **“Manual”**. The rollers must be open. In addition, switch off the motor and start the cool-down mode. Once the system has completely cooled down, the stuck welding material can be detached.

13. Accessories

Find out about the extensive range of accessories available at leister.com.

Use only Original Leister spare parts and accessories since otherwise, no warranty or guarantee claims can be asserted. You can find more information at leister.com.

14. Add-ons

14.1 Monitoring

This machine add-on allows both the air volume and temperature welding parameters to be monitored. If the parameters fall outside the defined limits, the system will emit a visual and acoustic alarm. The limits can be set as desired by the user. Furthermore, the monitoring unit is equipped with a remanent memory. This allows the operating hours of the machine, the air pump and the heating element to be recorded. It also records the number of heating cycles of the heating element.

14.1.1 Monitoring the Welding Parameters

The monitoring of both the air volume and temperature welding parameters can be activated via the **On/Off button** in the **Add-ons/Monitoring tab**.

	The monitoring of both the air volume and temperature welding parameters is deactivated .
	The monitoring of both the air volume and temperature welding parameters is activated .

14.1.2 Temperature

A limit value for the temperature deviation can be set to monitor the temperature. If the actual value exceeds this temperature range, this is indicated by a visual alarm. During welding, an acoustic alarm is emitted in addition to the visual alarm.

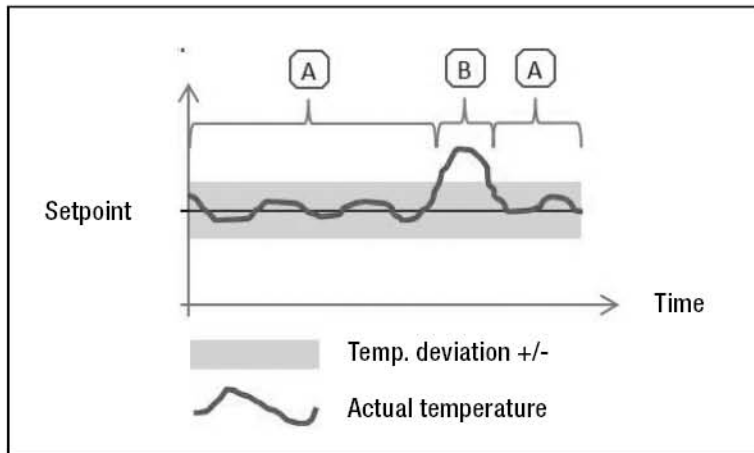



A	Within the limits	Green lamp signal.	
B	Outside the limits	Heating/cooling or standby phase Red lamp signal.	
B	Outside the limits	During welding, an alarm is emitted in addition to the red lamp .	

14.1.3 Air Volume

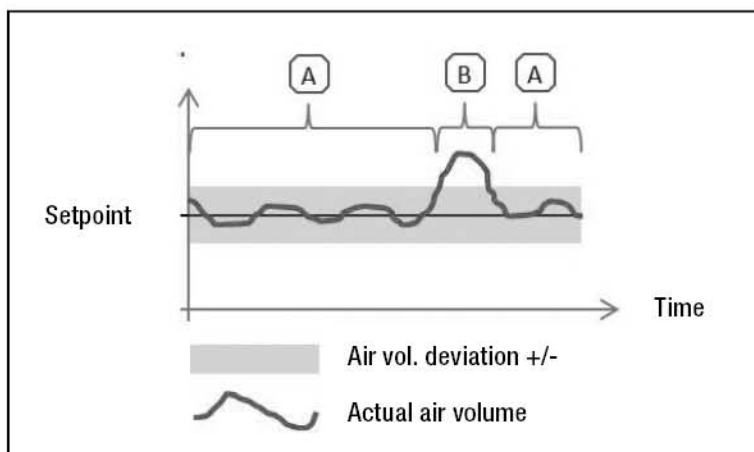

A limit value for the air volume deviation can be set to monitor the air volume. If the actual value exceeds this air volume range, this is indicated by a visual alarm. During welding, an acoustic alarm is emitted in addition to the visual alarm.

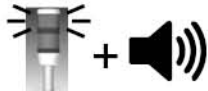

A	Within the limits	Green lamp signal.	
B	Outside the limits	Heating/cooling or standby phase Red lamp signal.	
B	Outside the limits	During welding, an alarm is emitted in addition to the red lamp.	

14.1.4 Operating Hours Counter

The operating hours counter is active as soon as the monitoring unit is connected. The operating hours counter remains active when the monitoring unit is switched off .

Machine operating hours	Counts the operating hours of the Seamtek 900 AT. This value cannot be reset.
Air pump operating hours	Counts the operating hours of the air pump. This value can be reset via the  symbol.
Heating operating hours	Counts the operating hours of the heating element. This value can be reset via the  symbol.
Number of heating cycles	Measures the number of heating cycles of the heating element. The number of heating cycles is incremented by 1 as soon as the actual temperature is at least 200 °C/ 392 °F and reaches at least 90% of the target temperature. If the actual temperature falls below 120 °C again, the number of heating cycles can be incremented again under the above conditions. The number of heating cycles can be reset via the symbol  .

15. Service and Repair

Repairs must only be carried out by authorized Leister service centers.

Leister service centers guarantee a professional and reliable repair service with original spare parts in accordance with circuit diagrams and spare parts lists. You will find the address of your authorized service center on the last page.

You can find more information at leister.com.

16. Training Course

Leister Technologies AG and its authorized service centers offer welding courses and training sessions.

You can find more information at leister.com.

17. Warranty

- The guarantee or warranty rights granted for this device by the direct distribution partner/salesperson apply from the date of purchase.
- In the event of a guarantee or warranty claim (verification by invoice or delivery note), manufacturing or processing errors will be rectified by the sales partner through replacement delivery or repair.
- Other guarantee or warranty claims are excluded within the framework of mandatory law.
- Damages resulting from natural wear, overload, or improper handling are excluded from the warranty.
- Heating elements shall be excluded from warranty obligations or guarantees.
- No guarantee or warranty claims exist for devices which have been converted or changed by the purchaser or for which non-original Leister spare parts have been used.

18. Declaration of Conformity

EU Declaration of Conformity

Leister Technologies AG, Galileo-Strasse 10, CH-6056 Kägiswil, Switzerland confirms that in the model made available for purchase, this product fulfills the requirements of the following EU directives.

Guidelines: 2006/42/EC, 2014/30/EU, 2011/65/EU
Harmonized standards: EN ISO 12100, EN 61000-6-4, EN 61000-6-2, EN 61000-3-12, EN 61000-3-11 (Z_{max}), EN 62311, EN 60204-1, EN IEC 63000

Kaegiswil, 04/15/2021

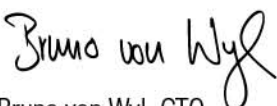
Bruno von Wyl, CTO



Christoph Baumgartner, GM

UK Declaration of Conformity

Leister Technologies AG, Galileo-Strasse 10, 6056 Kägiswil, Switzerland confirms that this product in the version put into circulation by us, fulfils the requirements of the following UK Statutory Instruments.

Directives: 2008 No. 1597, 2016 No. 1091, 2012 No. 3032
Harmonized Standards: EN ISO 12100, EN 61000-6-2, EN 61000-6-4, EN 61000-3-11, EN 61000-3-12, EN 62311, EN 60204-1, EN IEC 63000

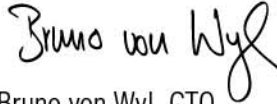
Kaegiswil, 04/01/2021

Bruno von Wyl, CTO

Christoph Baumgartner, GM

19. Disposal



Do not dispose of electrical equipment with household refuse.

Electrical appliances, accessories and packaging should be recycled in an environmentally friendly manner. When you are disposing of our products, please observe the national and local regulations.

20. Quick Reference Guide

20.1 Switching on/Starting

1. Make sure that the **main switch (5)** is switched off and the **welding nozzle (12)** is in parking position.
2. Connect the pneumatic system. Check the pneumatic regulator to see whether at least 6.5 bar is available.
3. Connect the supply voltage plug.
4. Switch on the **main switch (5)**.
5. Switch the **welding nozzle (12)** and **transport rollers (9)** to AUTO.
6. Select/set the welding parameters.
7. Switch on the heater with the **Heater On/Off button**; wait three to five minutes until the desired temperature is reached.
8. The welding process automatically starts when the **pedals (7, B)** are pressed.

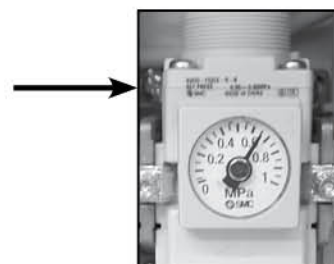

20.2 Switching Off

1. **Swivel the hot-air blowers (8)** upward (stops the drive motor).
2. Switch off the heater with the **Heater On/Off button**.
3. Wait for the end of the cool-down process (approx. six minutes).
4. Switch off the **main switch (5)**.
5. Pull out the supply voltage plug.

21. Appendix

E-Puller Set Up

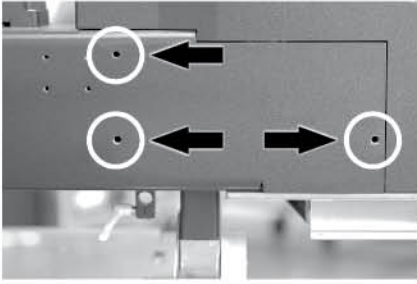

1. Mount the puller with the three M8 screws (included) on the frame.

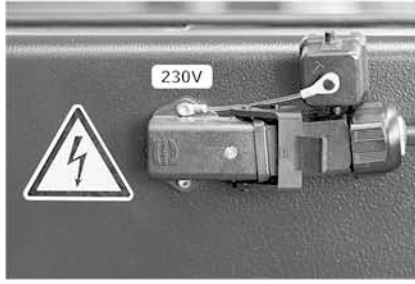

2. Connect power cable.



3. Connect network cable.

Once mounted, proceed with the alignment.

4. Loosen the three, M8 screws for lateral alignment. Make sure to align exactly with the main rollers.

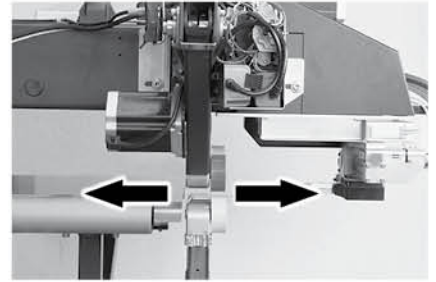
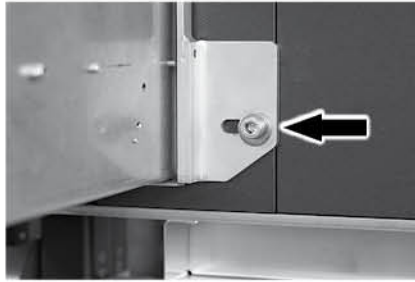
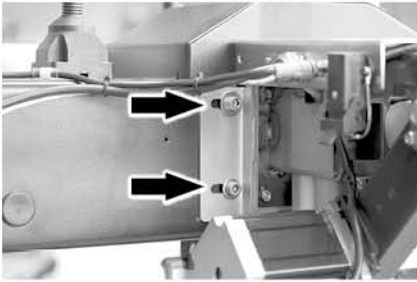

5. Loosen the four, M6 screws to adjust the angle of the upper roller. Make sure to have it flat on the lower roller.

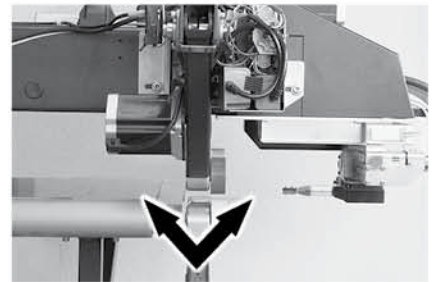
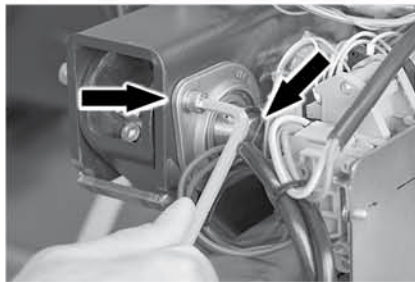
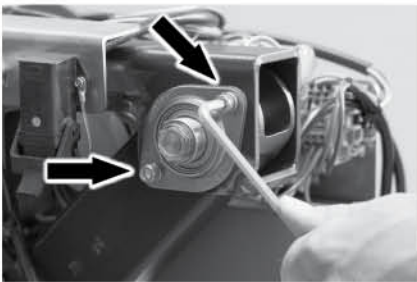

6. Loosen the eight, M4 screws to adjust the alignment of the lower roller.

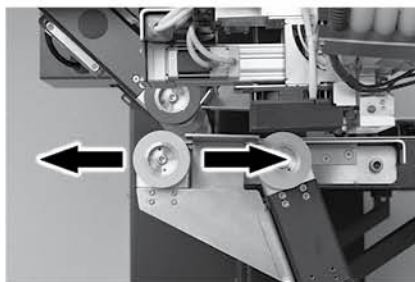
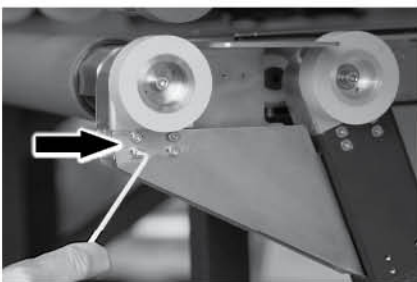

Puller and Table 2000 E set up

1. Loosen the six, M8 screws on the left and right puller unit and the four, M3 screws from the puller axle adjustment ring.

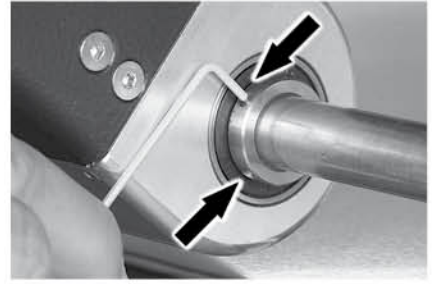
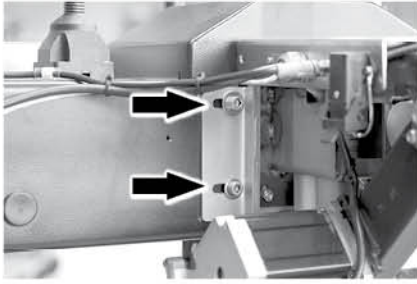

2. Insert the whole puller unit until it's linear to the front roller.

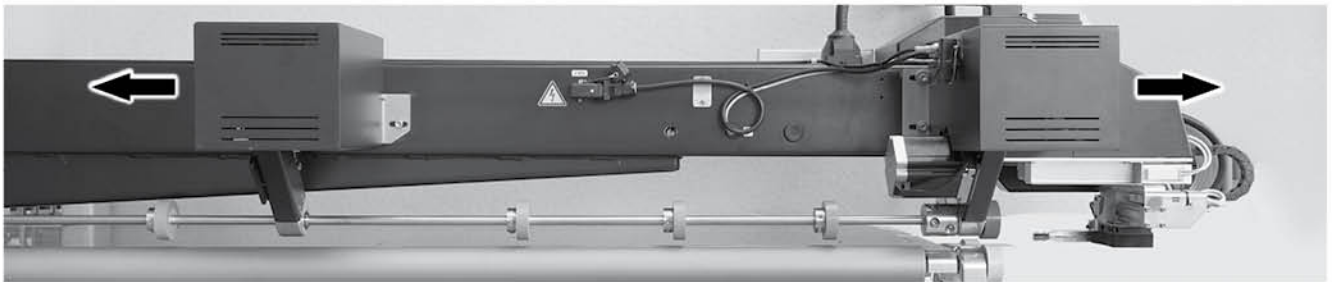

3. Adjusting the puller wheels to your needs.

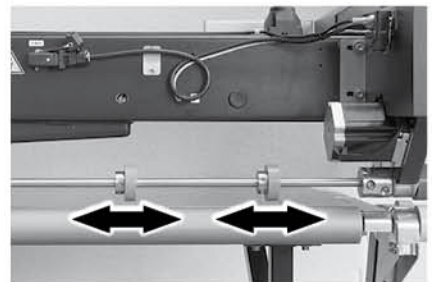
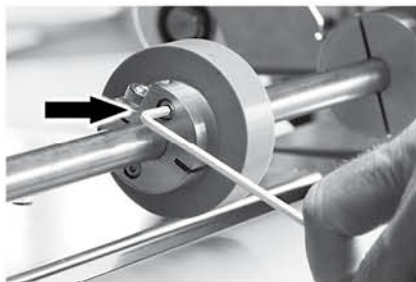
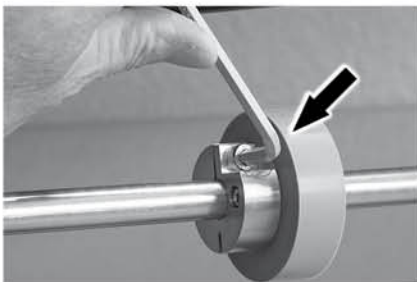

4. To adjust the table rollers, loosen the four, M10 screws. Now you can adjust the roller distance to the table (parallel) and the horizontal alignment with the two, M10 set screws.

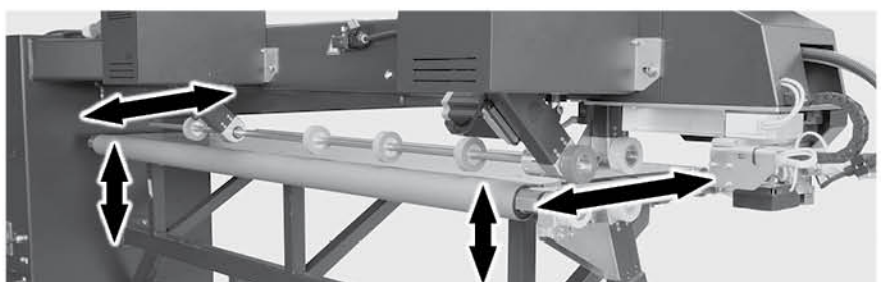
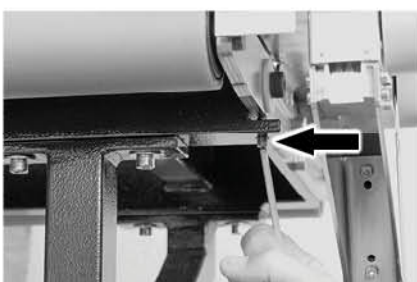
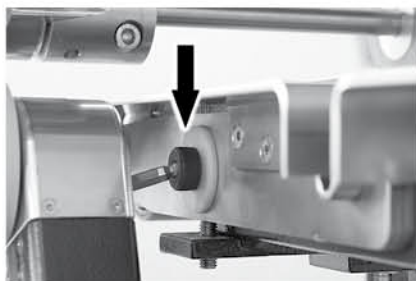
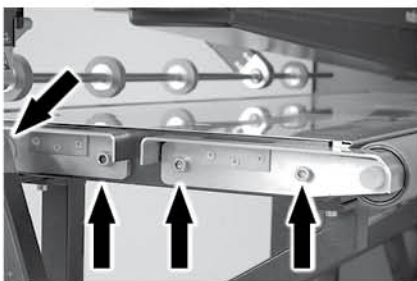

Please select your type of puller:

P-Puller = Pneumatic Puller (you have a pneumatic connection)

E-Puller = Electronic Puller (you don't have a pneumatic connection)

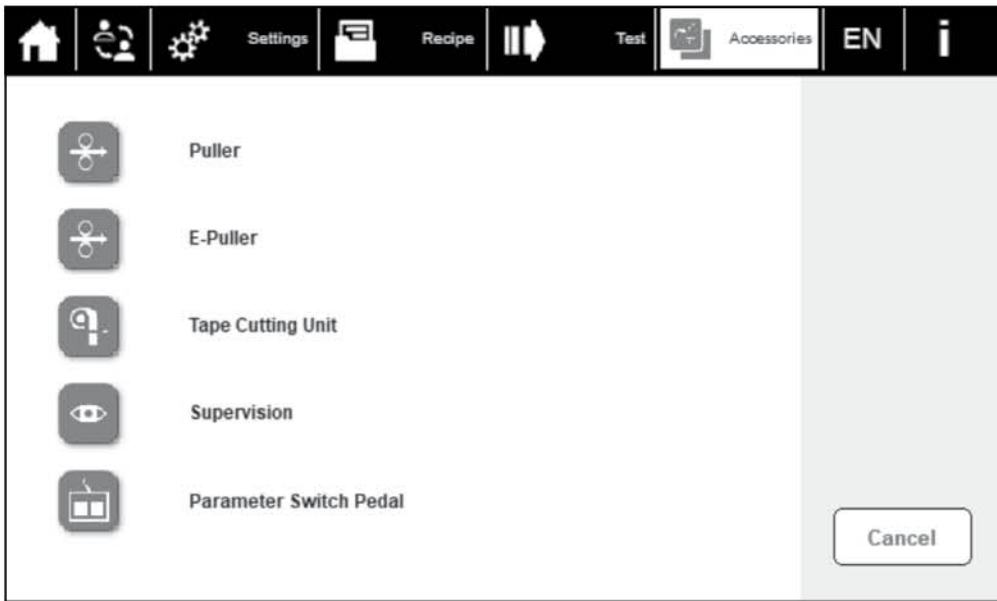

Activate the Puller on the HMI:

1. Go to the "Accessories" tab
2. Activate the Puller by pressing the "ON-OFF" Icon (green on, white off)

Adjust the Puller speed on the left side of the screen (speeds are adjusted in percentages). If the speed is set to 5%, the puller wheel will rotate 5% faster than the wheel of the base machine. This value is usually selected at 2-5%.

Note:

The Puller has to be connected. If it isn't, check the electrical connections

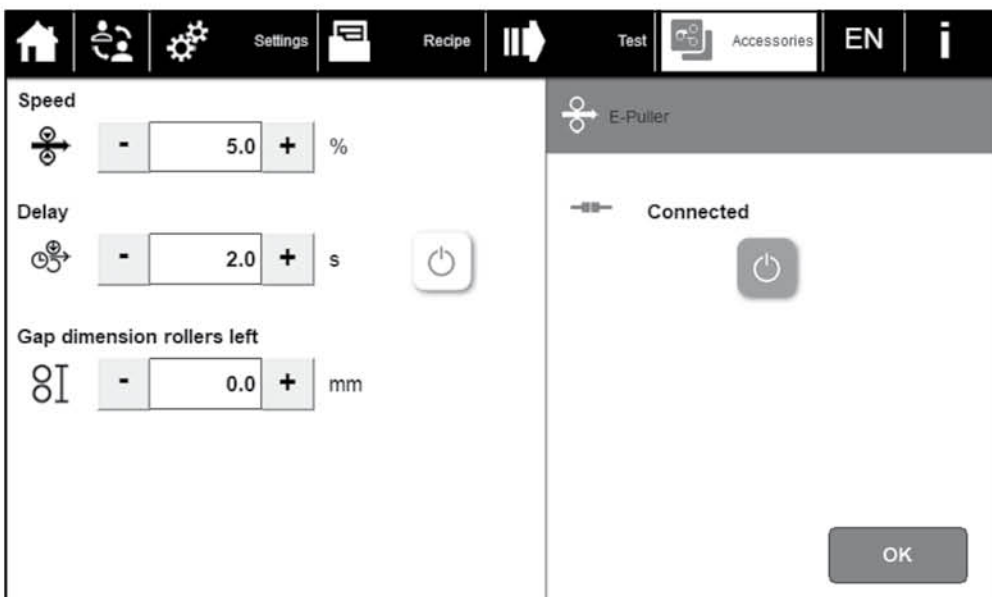

Raising the wheel

The Puller is operated with the base pedal. Push the "raise wheel" pedal and the top puller wheel will lift up. The top puller wheel follows the actions of the top pedestal wheel.

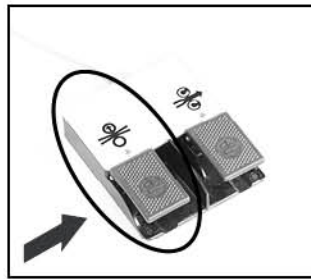

Starting

Press "start welding" pedal and the Puller will start running.

Go back to "Raise wheel" to stop.

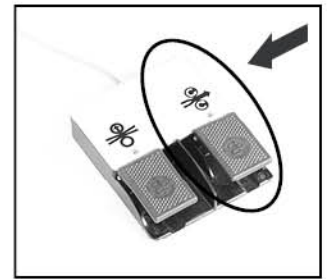

Delay

Activate and define puller delay

→ Activate the "Delay" by pressing the "ON-OFF" Icon (green on, white off)

The puller will clamp with the specified delayed value entered.



Clamp Clearance

Adjust clamp clearance to your desired value. If you decrease the clamp clearance, the pressure of the rollers on the material will increase.

On the 2000 version you have the option to adjust (define) the clamp clearance on the left and the right side independently. As soon as you activate the on/off button next to the gap dimension, the right selection will pop up.

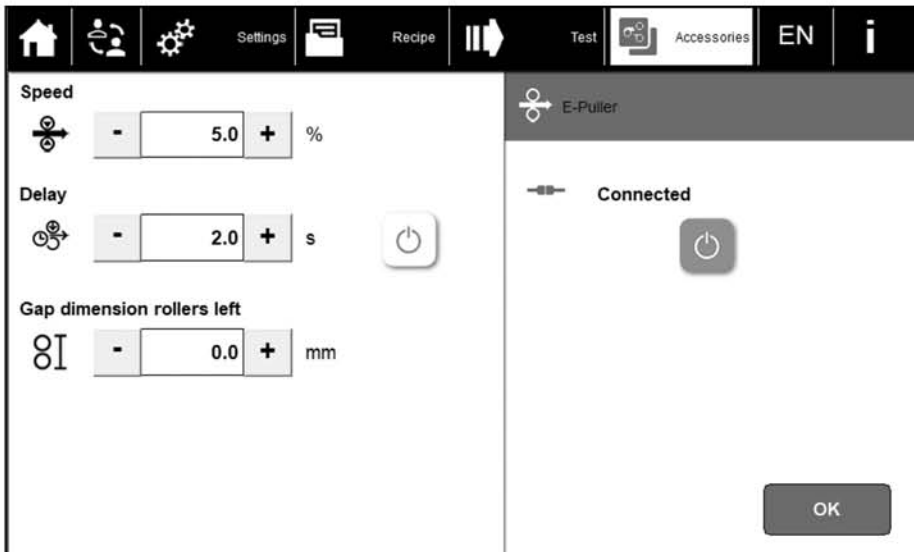

900 Version

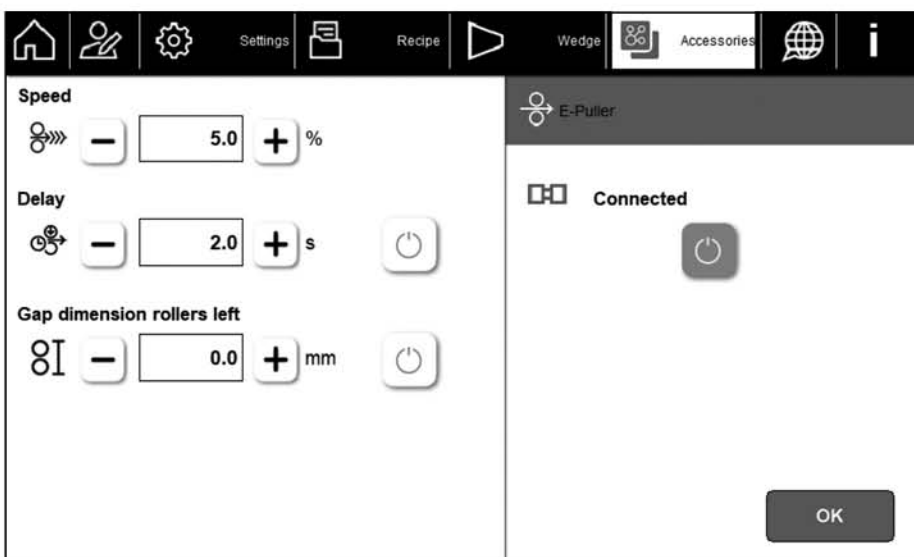

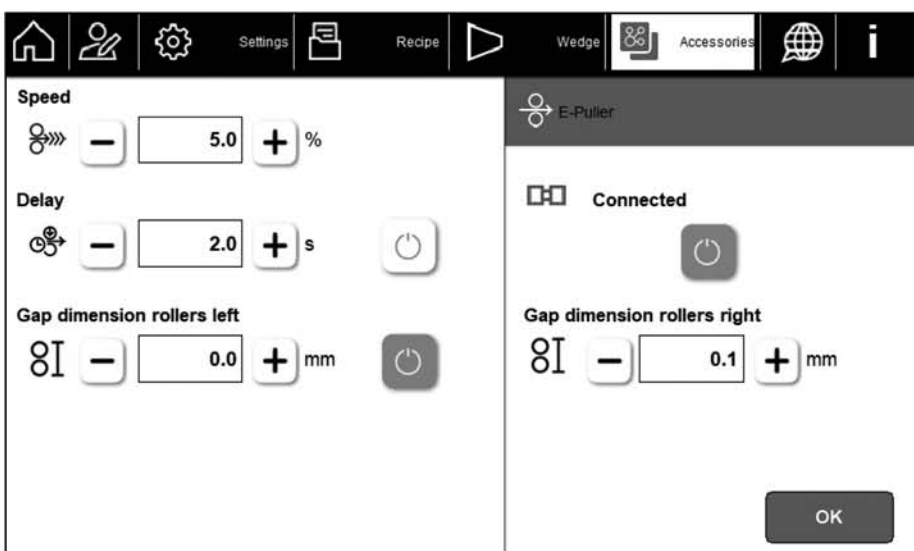

2000 Version
Same gap dimensions



2000 Version
Different gap dimensions

Calibrating the E-Puller

1. Switch on the device
2. Set clamping pressure  to automatic
3. Login admin mode
4. Go to "Extensions" → "E-Puller"
5. Set offset axis to "0"
6. Start calibration
7. Enter "5 mm" for clamp clearance
8. Press and release the "Raise wheel"  pedal (left pedal)
9. Measure the gap between the upper and lower puller wheel (mm)
10. Subtract 5 from the measured value (e.g. 4 mm - 5 mm = -1 mm)
11. Enter the number in the "Axis offset" field (e.g. -1 mm)
12. Start calibration
13. For 0 clearance, enter "0" in clearance
14. Press and release the "Raise wheel"  pedal (left pedal) again
15. The machine has been successfully calibrated and the puller is ready for use

Calibration of the Puller 2000

Same procedure like on the Puller E, additionally adjust your second Puller on the right manually.
Adjust the figure in the field "Gap dimension roller right" that your puller axle is horizontal in a open position.

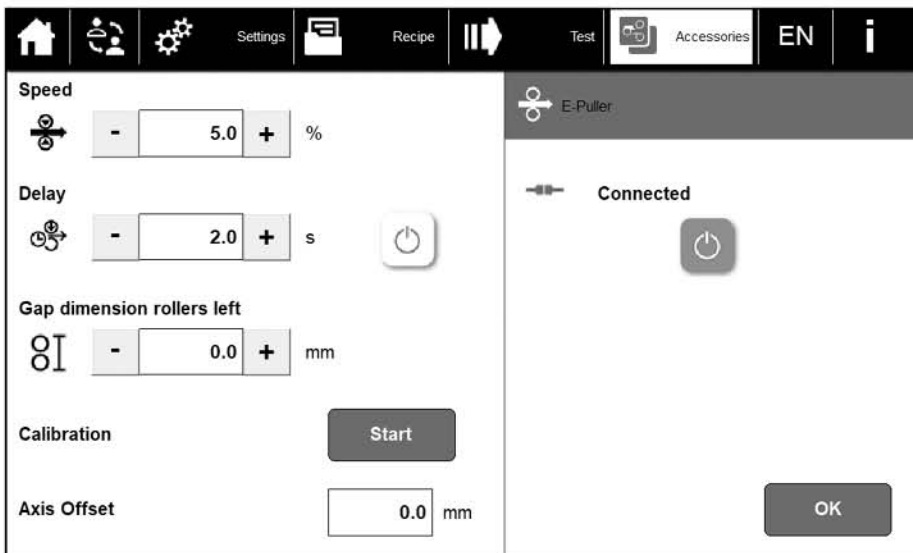

Puller 2000

Error Codes E-Puller

Error No.	Level	Info Text	Description
112	1	Warning 112: E-Puller could not reach Clamp Clearance.	Clamp Clearance is over the actual E-Puller position. → increase clamp clearance
296	2	Error 296: E-Puller Motor Driver Error.	Driver error (E-Puller). Check for Overload. → material jammed, increase clamp clearance
297	2	Error 297: E-Puller Calibration Error.	Check E-Puller machine setup.

[AF30, 40-A]

<Disassembly>

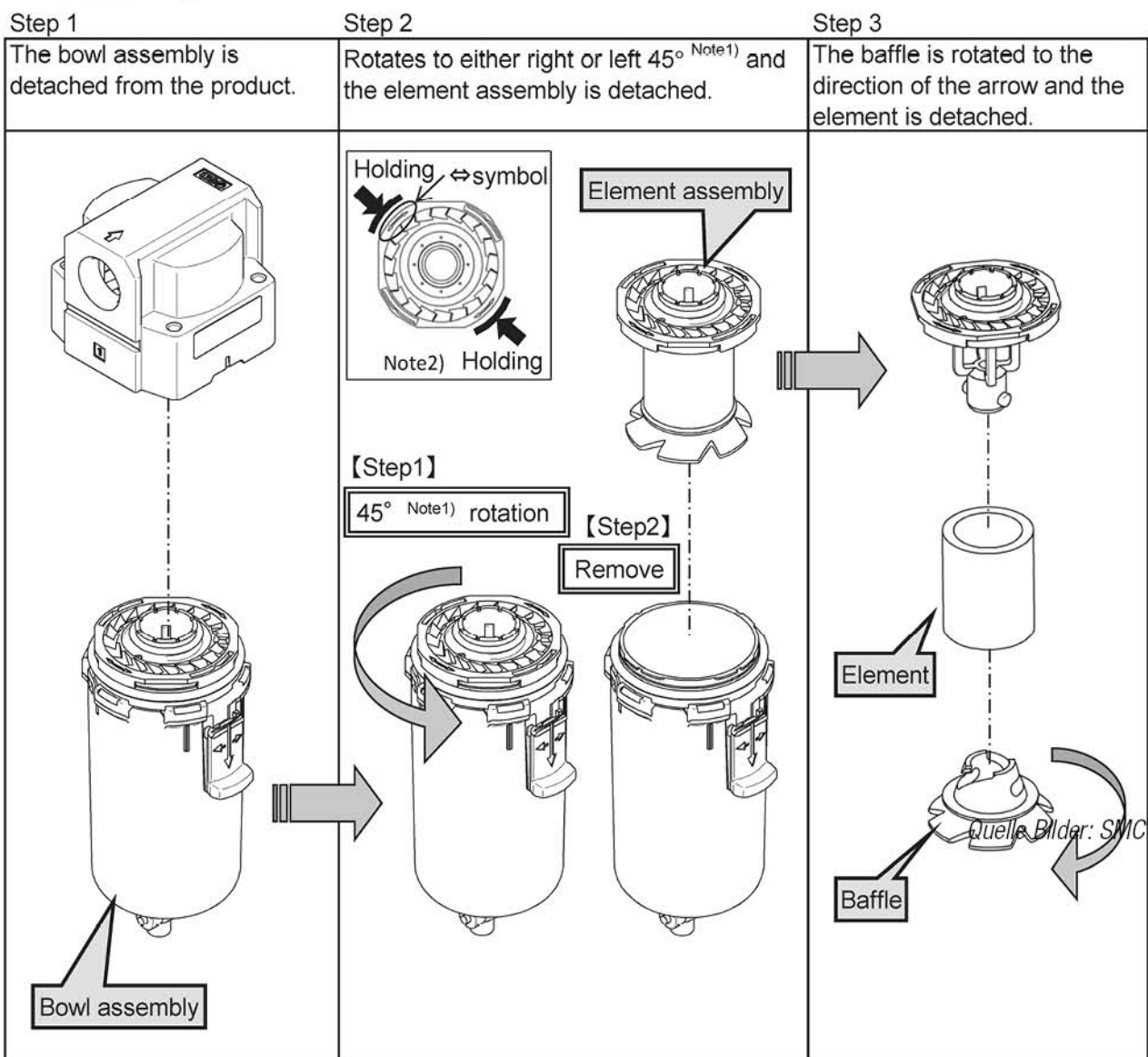

Note 1) Rotate 90 degrees to remove when -2 (Metal bowl), -8 (Metal bowl with level gauge).

Note 2) Rotate the element assembly holding the outer surface of the ⇄ symbol.

[AF30, 40-A]

<Assembly>

Step 1

The element is attached to the deflector, and fixed into position in the direction shown.

Step 2

To attach element assembly to the bowl assembly. Concave of the bowl assembly is combined with convex of the element assembly. Rotate to either right and left by 45°.

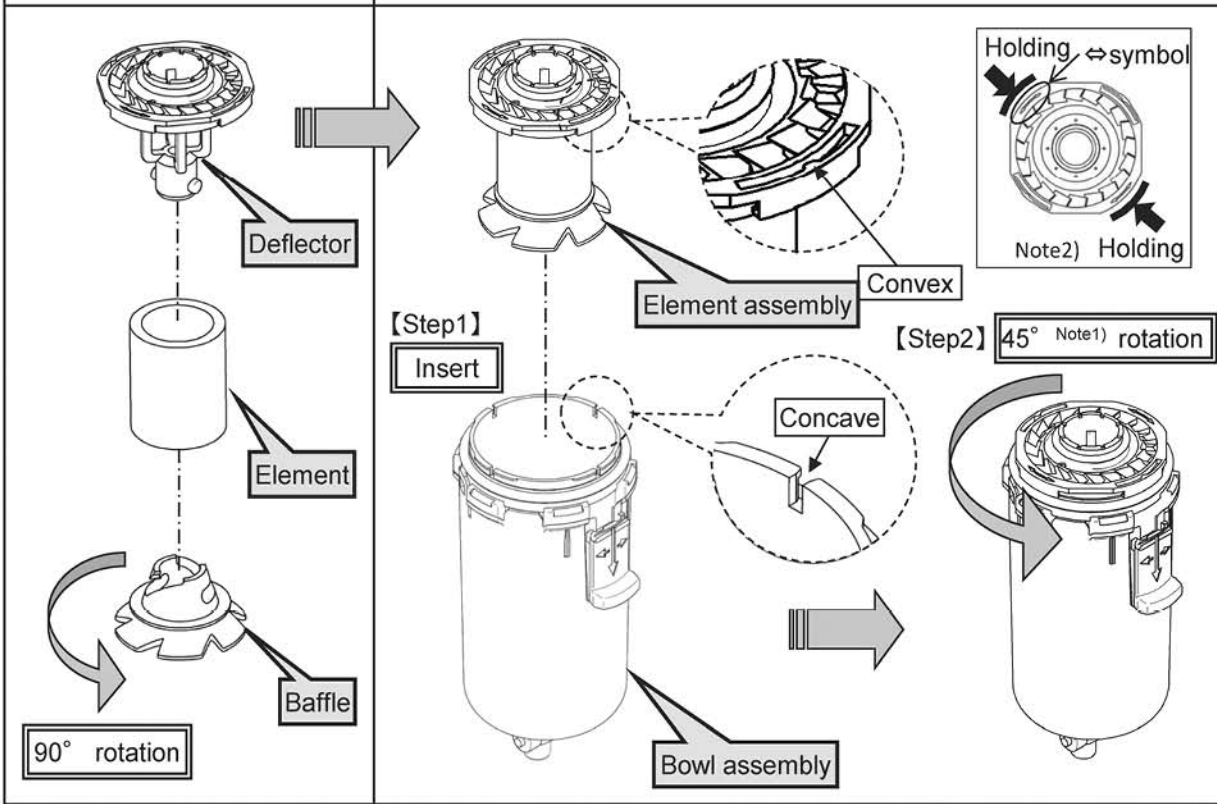

Step 3

The bowl assembly is rotated until the bowl assembly is attached to the product, and the lock button clicks into body when locked in position.

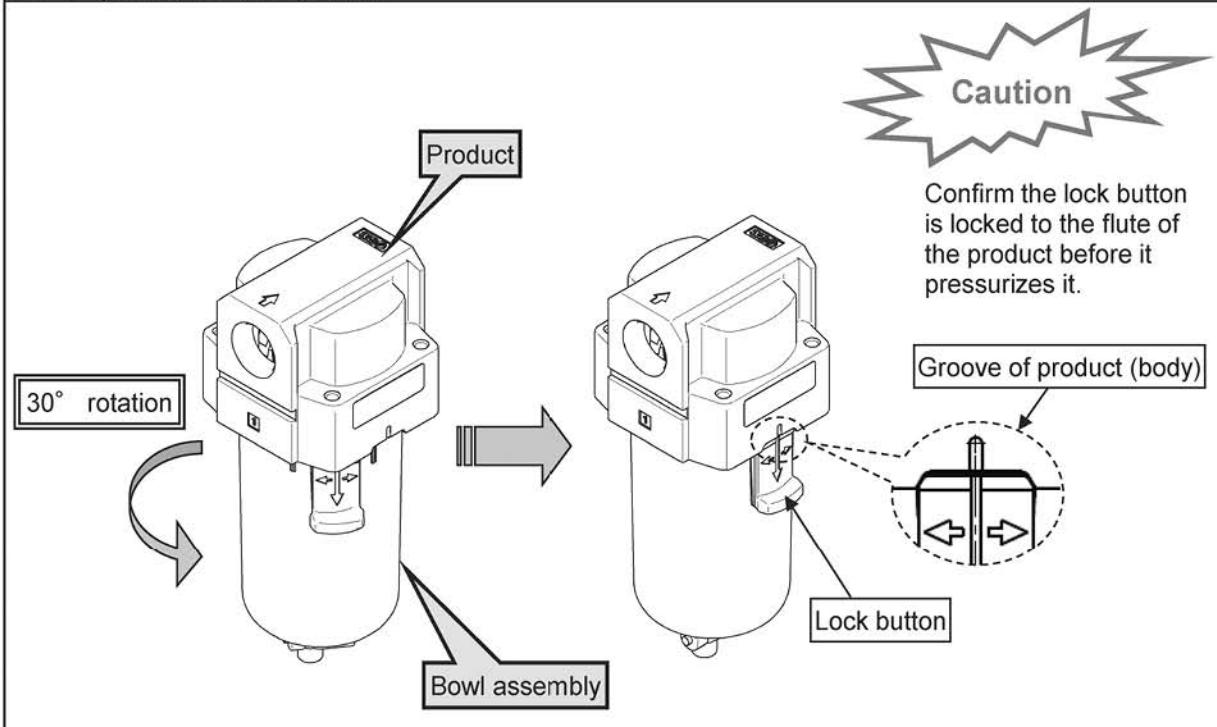

Note 1) Rotate 90 degrees to remove when -2 (Metal bowl), -8 (Metal bowl with level gauge).

Note 2) Rotate the element assembly holding the outer surface of the ↔ symbol.

9. REPLACEMENT PROCEDURE

WARNING

- Before replacement, ensure that the filter regulator is not pressurized.
- Rotate the pressure adjusting handle to zero.
- Replace referring to "10. DISASSEMBLY DRAWING" (P32 to P35).
- After replacement, ensure that specified function is satisfied and external leakage is not found before starting operation.

1) Bowl assembly / element

[AW10-A]

<Disassembly>

Step 1

The bowl assembly is released counterclockwise, detaches it from the product. If the bowl assembly is tightened too much to be removed, use hook spanner until it can be loosened by hand.
(Hook spanner nominal: :25/28)

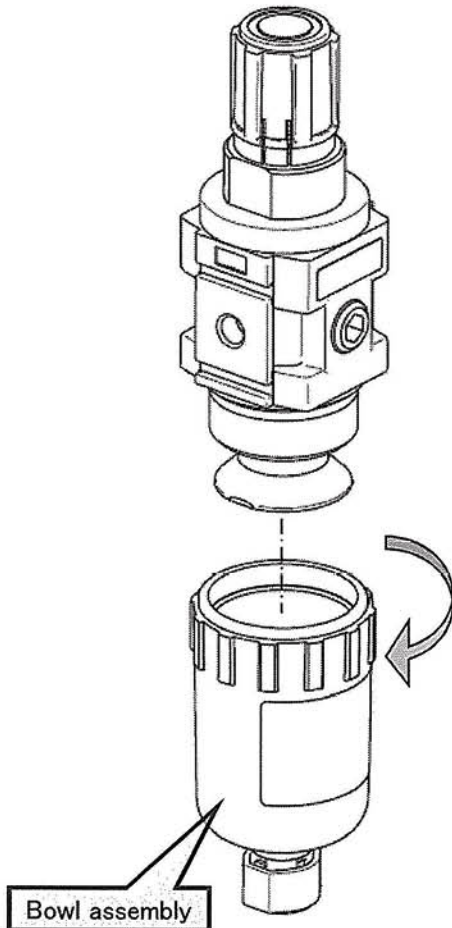

Step 2

Rotate the baffle by hand and counterclockwise to remove the baffle and element.

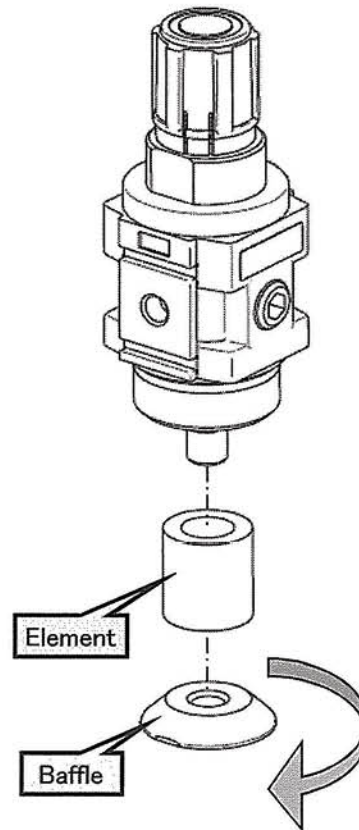

[AW10-A]

<Assembly>

Step 1

Mount the element to the element guide. (Direction is not specified.)

Step 2

Hold the baffle by hand to rotate it clockwise and mount the element. Baffle has mount direction. See disassembly drawing. Tighten by hand is the followed tightening to torque level shown.

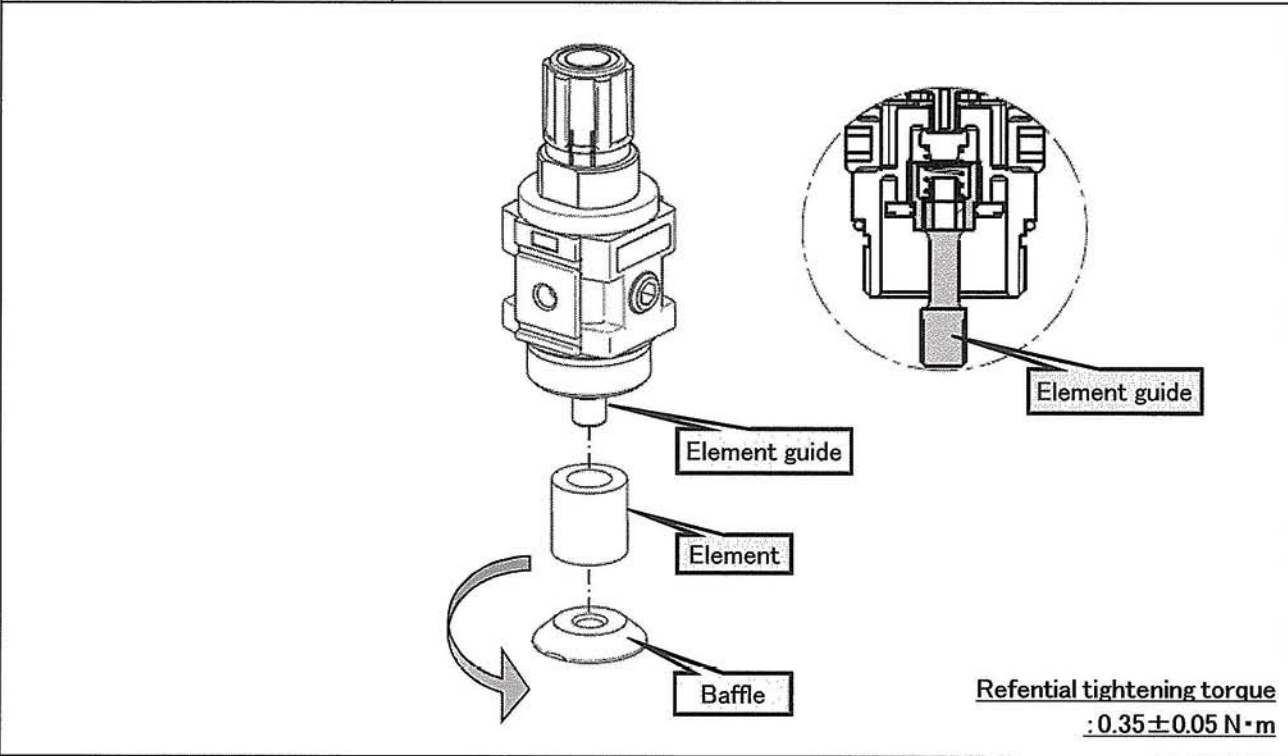

Step 3

Hold the bowl assembly by hand and rotate clockwise. Tighten by hand is the followed tightening to torque level shown.

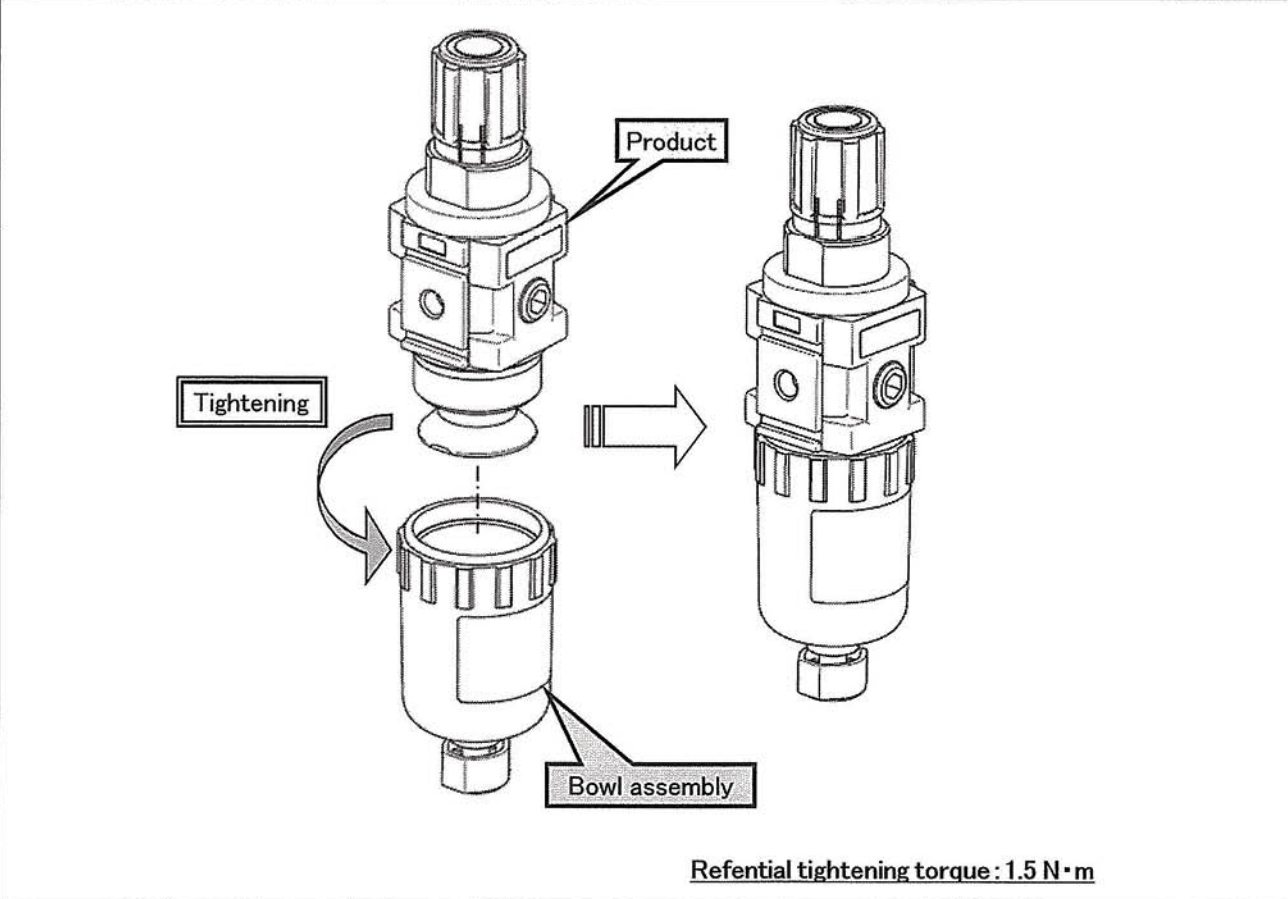

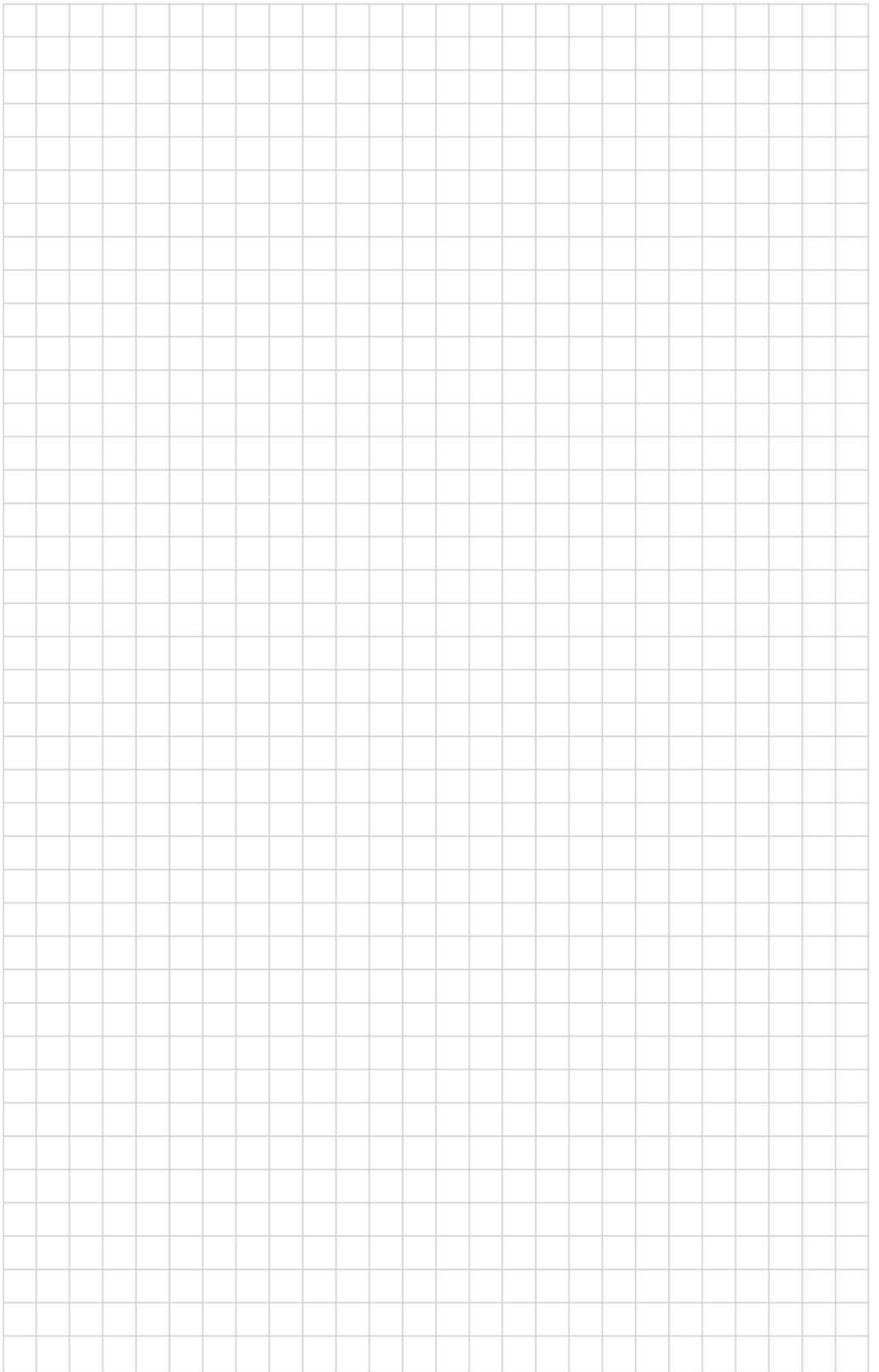



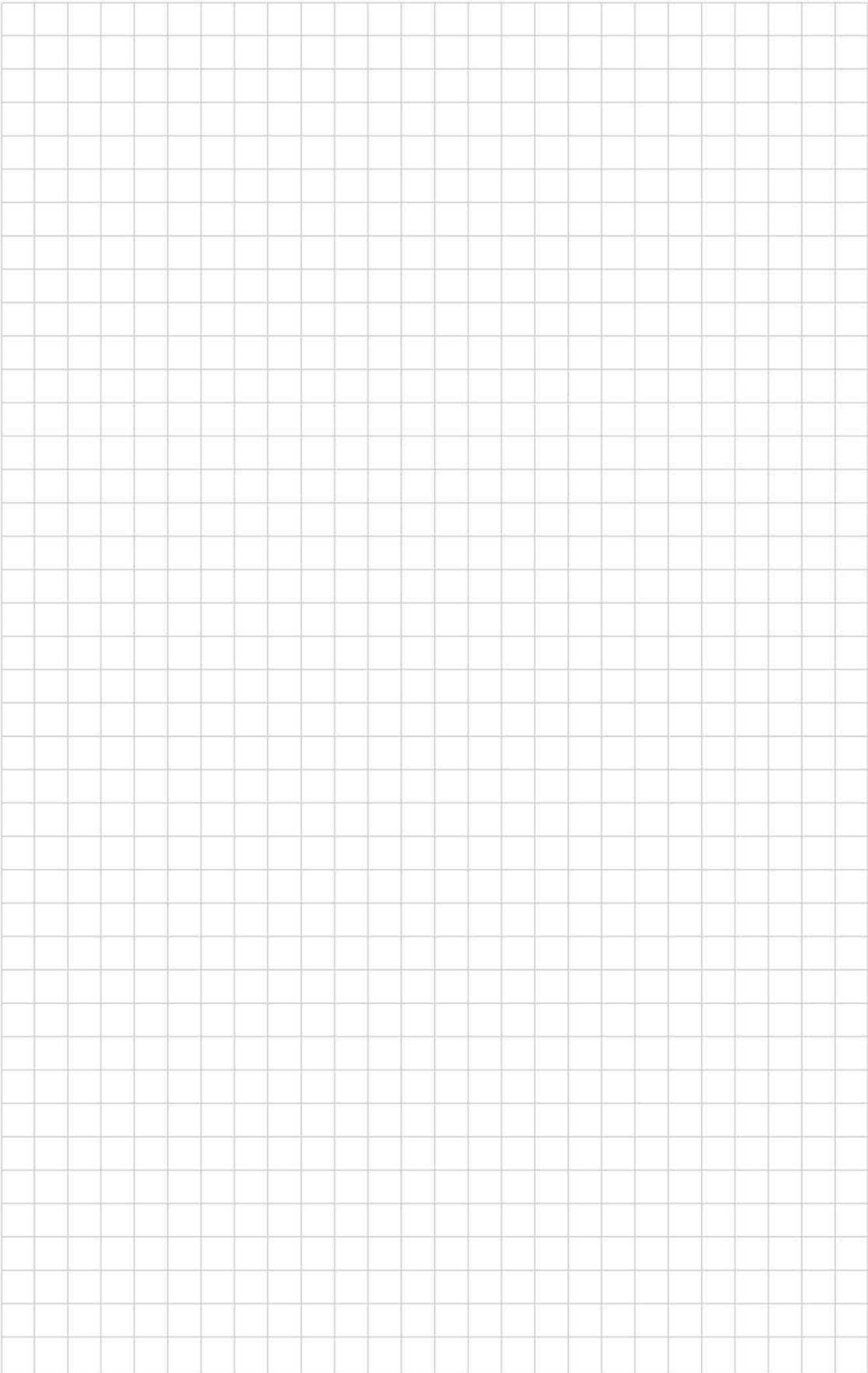



Your authorised Service Centre is:

Leister Technologies AG
Galileo-Strasse 10
6056 Kaegiswil/Switzerland
Tel. +41 41 662 74 74
Fax +41 41 662 74 16
leister.com
sales@leister.com